

TVS DIODES

Datasheet.Support

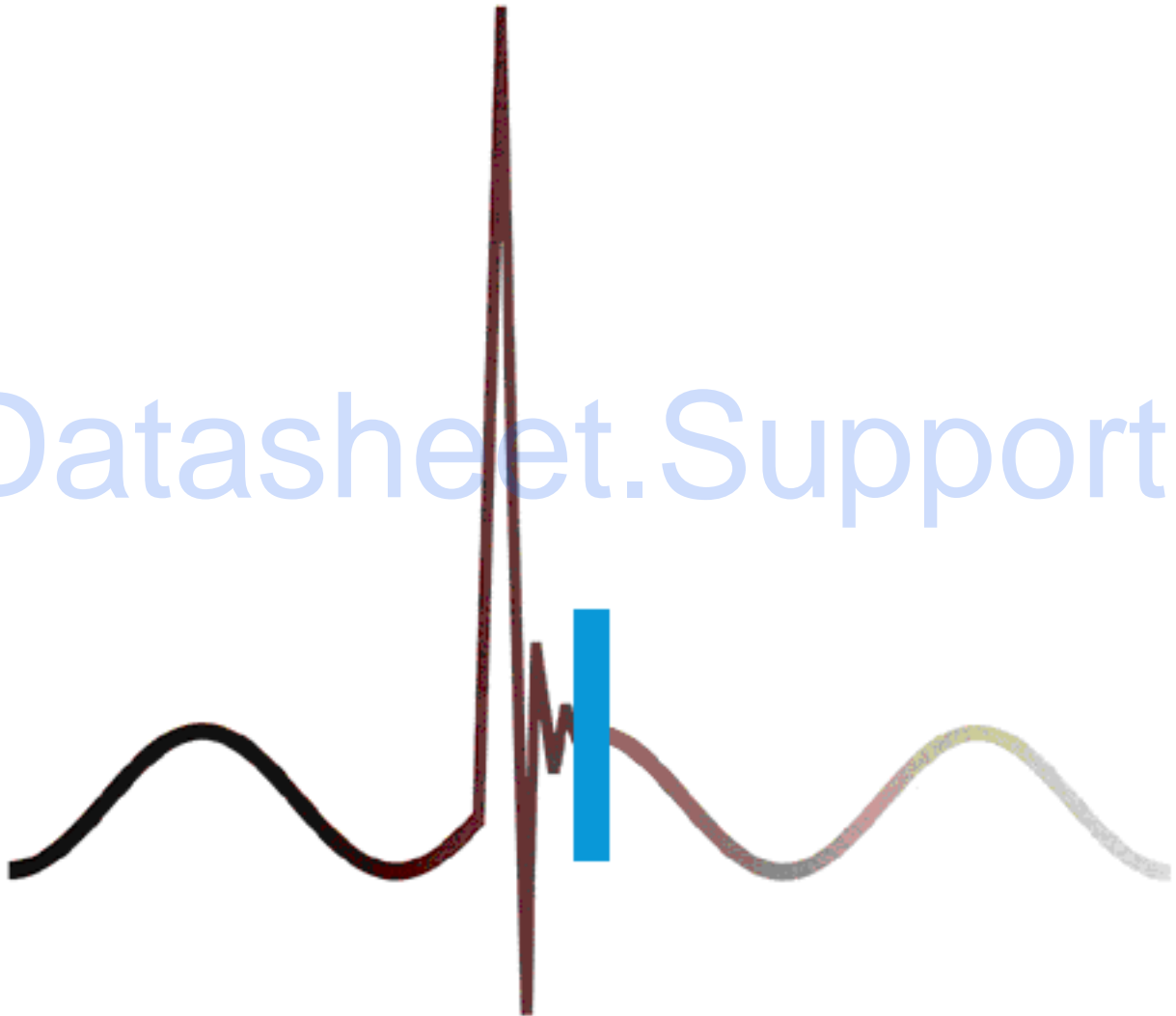

Protection Products Group



WORLD PRODUCTS INC.

# Transient Voltage Suppression Diodes

The Protection Products Group of World Products Inc. is committed to providing the optimum products for your transient/surge protection problems. Our TVS Diode satisfies the toughest requirements for a low clamping device and provides superior performance in all applications.

*World Products expands your options . . . . Large selection of equivalents to essentially all TVS Diodes. World Products specifications are designed to provide all of the necessary physical and electrical parameters required for proper component selection.*

***Discover why the first choice in TVS Diodes is WPI.***

## Table of Contents

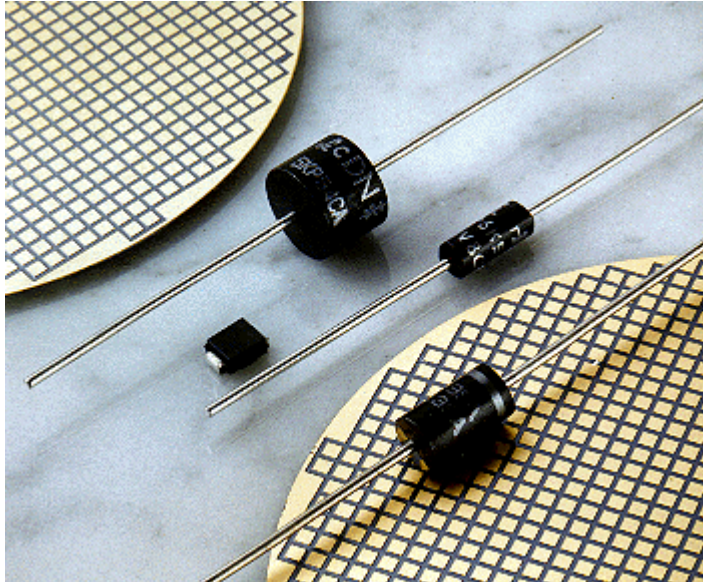
General Information	Selecting the Correct Part Type, Definition of Terms, General Characteristics.	
Axial Type		
P4KE Series	400 Watt	
SA Series	500 Watt	
P6KE Series	600 Watt	
1.5KE Series	1500 Watt	
3KP Series	3000 Watt	
5KP Series	5000 Watt	
15KP Series	15000 Watt	
Surface Mount		
P6SMBJ Series	600 Watt	
1.5SMCJ Series	1500 Watt	
P4SMAJ Series	400 Watt	
3.0SMCJ Series	3000 Watt	
Circuit Examples	Data Line Protection, AC Line Protection, Telecom Circuit Protection	

# Transient Voltage Suppression Diodes

## General Information

### TVS Diode Technology

World Products Transient Voltage Suppression (TVS) Diodes are silicon avalanche devices designed, manufactured, specified and tested according to voltage suppression applications.

These devices, with their fast response and low clamping characteristics, protect all MOS technology based devices, hybrids, and other voltage sensitive components. The low clamping factor and pico-second response time of World Products TVS Diodes clamps transient pulses early and maintains them at an acceptable level for their entire duration. In other overvoltage protection devices, response times are delayed by 24nS to 2µs allowing transients to reach dangerous levels. World Products TVS Diodes are designed to meet a 1.30 maximum clamping factor at their rated peak impulse current. This can be compared to clamping factors of 2 to 5 found in other protection devices.

### TVS Diode Applications

TVS Diodes are the optimum choice in protecting computer or data processor circuits and power supplies, airframe avionics and controls, numerically controlled machines, telecom circuits, and many other applications. These devices are designed to protect against transient voltages generated by lightning, electro-static discharge (ESD), and inductive switching.

### Selecting the Correct Part Type

The following guidelines should be observed in selecting the correct diode:

TVS Parameters		Application Parameters
1. Stand-off Voltage (V <sub>wm</sub> )	>=	Operating Voltage (V <sub>op</sub> )
2. Peak Pulse Current (I <sub>ppm</sub> )	>=	Source Transient Current (I <sub>s</sub> )
3. Clamping Voltage (V <sub>c</sub> )	=<	Voltage Withstand (V <sub>ws</sub> )

1. If the stand-off voltage is less than the operating voltage of the application, the diode will continually clamp the circuit voltage.
2. The Peak Pulse Current (I<sub>ppm</sub>) is the maximum current the TVS can handle. The source transient current is determined by dividing the peak transient voltage by the source impedance - this is often difficult to determine. In many cases, however, this may be obtained from industry standard documents, customer requirements, etc.
3. Determine the maximum voltage level that the protected device can withstand (V<sub>ws</sub>). Select a suppressor which will clamp the transient at a lower level (V<sub>c</sub>).

Consider the transient source: lightning, electro-static discharge, inductive switching or nuclear explosion (NEMP). Often, a 1500 watt peak pulse rated device will protect against transients due to secondary lightning effects or inductive switching on power, data and telephone lines. A 500 watt device is sufficient to protect sensitive components against transients generated by electro-static discharge.



# Transient Voltage Suppression Diodes

## General Information - (Continued)

### Schematic Symbols

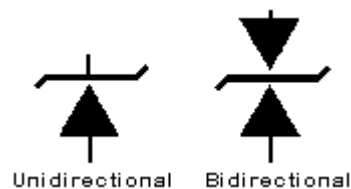

---

### Definitions of Terms

#### **V<sub>c</sub> Clamping Voltage:**

Peak voltage across the suppressor measured at a specific I<sub>ppm</sub>. (Note: due to thermal, reactive or other effects, peak voltage and peak current are not necessarily coincident in time.)

#### **I<sub>pp</sub> Peak Impulse Current:**

Peak current measured using a specified waveform.

#### **I<sub>ppm</sub> Rated Peak Impulse Current:**

Rated maximum value of peak impulse current (I<sub>pp</sub>) applied using a 10 x 1000μs waveform. (Minimum of 10 pulses applied.)

#### **V<sub>wm</sub> Rated Standoff Voltage:**

Maximum working (continuous) DC or peak voltage which may be applied over the standard operating temperature range. (Note: V<sub>wm</sub> of a selected device must be greater than or equal to the maximum operating voltage of the line to be protected.)

#### **I<sub>d</sub> Stand-By Current:**

Maximum current that flows through the suppressor at rated standoff voltage (V<sub>wm</sub>) at a specified temperature.

#### **V<sub>br</sub> Breakdown Voltage:**

The voltage measured across the suppressor at a specified DC test current (I<sub>t</sub>).

#### **I<sub>t</sub> Test Current:**

The specific DC current applied to the suppressor used to determine breakdown voltage (V<sub>br</sub>).

---

# Transient Voltage Suppression Diodes

## General Information - (Continued)

### Vbr Temperature Coefficient:

The ratio of change in breakdown voltage (Vbr) to changes in temperature. Expressed either as millivolts per degree centigrade (mV/°C) or percent change in breakdown voltage per degree centigrade (% Vbr/°C).

### Cf Clamping Factor:

Ratio of the measured clamping voltage (Vc) at specified peak pulse current (Ipp) to breakdown voltage (Vbr) on a specific device.

$$Cf = \frac{Vc}{Vbr}$$

### C Capacitance:

Capacitance between the two terminals of a suppressor measured at a specific frequency and bias voltage.

### Pppm Rated Multiple Peak Pulse Power:

Derived by multiplying the maximum clamping voltage (Vc) times the Rated Peak Impulse Current (Ippm).

### Ifsm Rated Forward Surge Current:

Unidirectional devices only. Maximum forward current during a 8.3ms half sine wave of AC line frequency (60Hz).

### Impulse Current Waveform

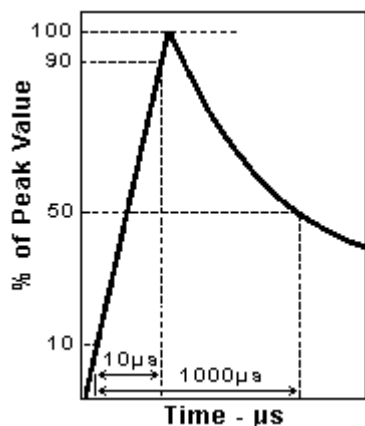

# Transient Voltage Suppression Diodes

## General Information - (Continued)

### Mechanical Characteristics

Case: UL94V-0 Molded Epoxy

Leads: Tinned Copper

Solderability: Military Standard 202E Method 208C

Marking: World Products Logo, Part Number and EIA Date Code

Method Available: Tape and Reel to EIA-296-D

### Part Numbering System

Example - SA170A			
SA	170		A
Series	Voltage	Polarity	Tolerance
Axial Type		Blank=Unipolar C=Bipolar	Blank=10% A=5%
P4KE = 400 Watt	Nominal Breakdown Voltage		
SA = 500 Watt	Rated Standoff Voltage		
P6KE = 600 Watt	Nominal Breakdown Voltage		
1.5KE = 1500 Watt	Nominal Breakdown Voltage		
3KP = 3000 Watt	Rated Standoff Voltage		
5KP = 5000 Watt	Rated Standoff Voltage		
15KP = 15000 Watt	Rated Standoff Voltage		
Surface Mount			
P4SMAJ = 400 Watt Surface Mount	Rated Standoff Voltage		
P6SMBJ = 600 Watt Surface Mount	Rated Standoff Voltage		
1.5SMCJ = 1500 Watt Surface Mount	Rated Standoff Voltage		
3.0SMCJ = 3000 Watt Surface Mount	Rated Standoff Voltage		

**TVS Diodes - 400 Watt Specifications - Electrical Characteristics**

Part Number*	Rated Standoff Voltage V <sub>wm</sub> (Volts)	Breakdown Voltage			Maximum Stand By Current @V <sub>wm</sub> + I <sub>d</sub> (μA)	10/1000μs Maximum Clamping Voltage @I <sub>ppm</sub> # V <sub>c</sub> Max (Volts)	10/1000μs Rated Peak Impulse Current I <sub>ppm</sub> # (Amperes)
		V <sub>br</sub> (Volts)	Min	Max			
P4KE6.8	5.50	6.12	7.48	10	1000	10.8	38.0
P4KE6.8A	5.80	6.45	7.14	10	1000	10.5	40.0
P4KE7.5	6.05	6.75	8.25	10	500	11.7	36.0
P4KE7.5A	6.40	7.13	7.88	10	500	11.3	37.0
P4KE8.2	6.63	7.38	9.02	10	200	12.5	33.0
P4KE8.2A	7.02	7.79	8.61	10	200	12.1	35.0
P4KE9.1	7.37	8.19	10.00	1	50	13.8	30.0
P4KE9.1A	7.78	8.65	9.55	1	50	13.4	31.0
P4KE10	8.10	9.00	11.00	1	10	15.0	28.0
P4KE10A	8.55	9.50	10.50	1	10	14.5	29.0
P4KE11	8.92	9.90	12.10	1	5	16.2	26.0
P4KE11A	9.40	10.50	11.60	1	5	15.6	27.0
P4KE12	9.72	10.80	13.20	1	5	17.3	24.0
P4KE12A	10.20	11.40	12.60	1	5	16.7	25.0
P4KE13	10.50	11.70	14.30	1	5	19.0	22.0
P4KE13A	11.10	12.40	13.70	1	5	18.2	23.0
P4KE15	12.10	13.50	16.50	1	5	22.0	19.0
P4KE15A	12.80	14.30	15.80	1	5	21.2	20.0
P4KE16	12.90	14.40	17.60	1	5	23.5	18.0
P4KE16A	13.60	15.20	16.80	1	5	22.5	19.0
P4KE18	14.50	16.20	19.80	1	5	26.5	16.0
P4KE18A	15.30	17.10	18.90	1	5	25.2	17.0
P4KE20	16.20	18.00	22.00	1	5	29.1	14.0
P4KE20A	17.10	19.00	21.00	1	5	27.7	15.0
P4KE22	17.80	19.80	24.20	1	5	31.9	13.0
P4KE22A	18.80	20.90	23.10	1	5	30.6	14.0
P4KE24	19.40	21.60	26.40	1	5	34.7	12.0
P4KE24A	20.50	22.80	25.20	1	5	33.2	13.0

\* = Add "C" or "CA" suffix for bidirectional device types.

+ = For Bidirectional Types Having V<sub>wm</sub> ≤ 10V, their I<sub>d</sub> limit is doubled.

# = See General Information for Impulse Current Waveform.

**TVS Diodes - 400 Watt Specifications - Electrical Characteristics - (Continued)**

Part Number*	Rated Standoff Voltage Vwm (Volts)	Breakdown Voltage			Maximum Stand By Current @Vwm+ Id ( $\mu$ A)	10/1000 $\mu$ s Maximum Clamping Voltage @Ippm# Vc Max (Volts)	10/1000 $\mu$ s Rated Peak Impulse Current Ippm# (Amperes)
		Vbr (Volts)	Min	Max			
P4KE27	21.80	24.30	29.70	1	5	39.1	11.0
P4KE27A	23.10	25.70	28.40	1	5	37.5	11.2
P4KE30	24.30	27.00	33.00	1	5	43.5	10.0
P4KE30A	25.60	28.50	31.50	1	5	41.4	10.0
P4KE33	26.80	29.70	36.30	1	5	47.7	9.0
P4KE33A	28.20	31.40	34.70	1	5	45.7	9.0
P4KE36	29.10	32.40	39.60	1	5	52.0	8.0
P4KE36A	30.80	34.20	37.80	1	5	49.9	8.4
P4KE39	31.60	35.10	42.90	1	5	56.4	7.4
P4KE39A	33.30	37.10	41.00	1	5	53.9	7.8
P4KE43	34.80	38.70	47.30	1	5	61.9	6.8
P4KE43A	36.80	40.90	45.20	1	5	59.3	7.1
P4KE47	38.10	42.30	51.70	1	5	67.8	6.2
P4KE47A	40.20	44.70	49.40	1	5	64.8	5.0
P4KE51	41.30	45.90	56.10	1	5	73.5	5.7
P4KE51A	43.60	48.50	53.60	1	5	70.1	6.0
P4KE56	45.60	50.40	61.60	1	5	80.5	5.2
P4KE56A	47.80	53.20	58.80	1	5	77.0	5.5
P4KE62	50.20	55.80	68.20	1	5	89.0	4.7
P4KE62A	53.00	58.90	65.10	1	5	85.0	5.0
P4KE68	55.10	61.20	74.80	1	5	98.0	4.3
P4KE68A	58.10	64.60	71.40	1	5	92.0	4.6
P4KE75	60.70	67.50	82.50	1	5	108.0	3.9
P4KE75A	64.10	71.30	78.80	1	5	103.0	4.1
P4KE82	66.40	73.80	90.20	1	5	118.0	3.6
P4KE82A	70.10	77.90	86.10	1	5	113.0	3.7
P4KE91	73.70	81.90	100.00	1	5	131.0	3.2
P4KE91A	77.80	86.50	95.50	1	5	125.0	3.4

\* = Add "C" or "CA" suffix for bidirectional device types.

+ = For Bidirectional Types Having Vwm  $\leq$  10V, their Id limit is doubled.

# = See General Information for Impulse Current Waveform.



**TVS Diodes - 400 Watt Specifications - Electrical Characteristics - (Continued)**

Part Number*	Rated Standoff Voltage Vwm (Volts)	Breakdown Voltage		Maximum Stand By Current @Vwm+ Id (mA)	Maximum Stand By Current @Vwm+ Id (μA)	10/1000μs Maximum Clamping Voltage @Ippm# Vc Max (Volts)	10/1000μs Rated Peak Impulse Current Ippm# (Amperes)
		Vbr (Volts) Min	@It Max				
P4KE100	81.00	90.00	110.00	1	5	144.0	2.9
P4KE100A	85.50	95.00	105.00	1	5	137.0	3.1
P4KE110	89.20	99.90	121.00	1	5	158.0	2.7
P4KE110A	94.00	105.00	116.00	1	5	152.0	2.8
P4KE120	97.20	108.00	132.00	1	5	173.0	2.4
P4KE120A	102.00	114.00	126.00	1	5	165.0	2.5
P4KE130	105.00	117.00	143.00	1	5	187.0	2.2
P4KE130A	111.00	124.00	137.00	1	5	179.0	2.3
P4KE150	121.00	135.00	165.00	1	5	215.0	2.0
P4KE150A	128.00	143.00	158.00	1	5	207.0	2.0
P4KE160	130.00	144.00	176.00	1	5	230.0	1.8
P4KE160A	136.00	152.00	168.00	1	5	219.0	1.9
P4KE170	138.00	153.00	187.00	1	5	244.0	1.7
P4KE170A	145.00	162.00	179.00	1	5	234.0	1.8
P4KE180	146.00	162.00	198.00	1	5	258.0	1.6
P4KE180A	154.00	171.00	189.00	1	5	246.0	1.7
P4KE200	162.00	180.00	220.00	1	5	287.0	1.5
P4KE200A	171.00	190.00	210.00	1	5	274.0	1.53
P4KE220	175.00	198.00	242.00	1	5	344.0	1.16
P4KE220A	185.00	209.00	231.00	1	5	328.0	1.22
P4KE250	202.00	225.00	275.00	1	5	360.0	1.10
P4KE250A	214.00	237.00	263.00	1	5	344.0	1.16
P4KE300	243.00	270.00	330.00	1	5	430.0	0.93
P4KE300A	256.00	285.00	315.00	1	5	414.0	0.97
P4KE350	284.00	315.00	385.00	1	5	504.0	0.79
P4KE350A	300.00	332.00	368.00	1	5	482.0	0.83
P4KE400	324.00	360.00	440.00	1	5	574.0	0.70
P4KE400A	342.00	380.00	420.00	1	5	548.0	0.73
P4KE440	356.00	396.00	484.00	1	5	631.0	0.66
P4KE440A	376.00	418.00	462.00	1	5	600.0	0.69

\* = Add "C" or "CA" suffix for bidirectional device types.

+ = For Bidirectional Types Having Vwm ≤ 10V, their Id limit is doubled.

# = See General Information for Impulse Current Waveform.

## TVS Diodes - 400 Watt Specifications - P4KE Series Features

### P4KE Series Features

- 400 watt peak pulse power dissipation
- Available in voltages from 6.8V to 440V
- Unidirectional and Bidirectional
- Glass passivated junction
- Low clamping factor
- Available in bulk or tape and reel (Reel quantity = 4,000 pieces)
- Each device 100% surge tested

### Absolute Maximum Ratings

- Peak pulse power dissipation (Pppm) at 25°C..... 400W
- Steady state power dissipation at lead temperature = 75°C (Lead length 3/8" min.)..... 1W
- Operating and storage temperatures..... -65°C to + 175°C

- UL497B, File # E135015

### Mechanical Dimensions

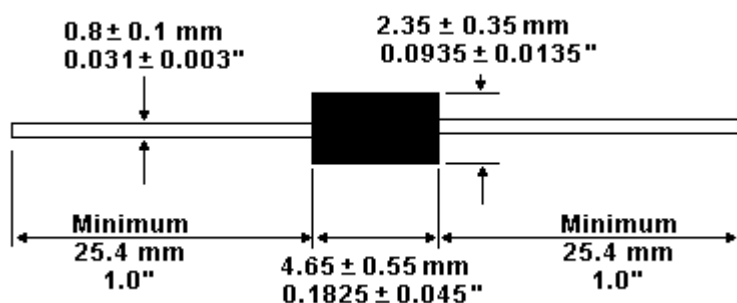

**TVS Diodes - 500 Watt Specifications - Electrical Characteristics**

Part Number*	Rated Standoff Voltage Vwm (Volts)	Breakdown Voltage			Maximum Stand By Current @Vwm+ Id (µA)	10/1000µs Maximum Clamping Voltage @Ippm# Vc Max (Volts)	10/1000µs Rated Peak Impulse Current Ippm# (Amperes)
		Vbr (Volts) Min	Max	@It (mA)			
SA5.0	5.0	6.40	7.30	10	600	9.6	52.0
SA5.0A	5.0	6.40	7.00	10	600	9.2	54.3
SA6.0	6.0	6.67	8.15	10	600	11.4	43.9
SA6.0A	6.0	6.67	7.37	10	600	10.3	48.5
SA6.5	6.5	7.22	8.82	10	400	12.3	40.7
SA6.5A	6.5	7.22	7.98	10	400	11.2	44.7
SA7.0	7.0	7.78	9.51	10	150	13.3	37.8
SA7.0A	7.0	7.78	8.60	10	150	12.0	41.7
SA7.5	7.5	8.33	10.2	1	50	14.3	35.0
SA7.5A	7.5	8.33	9.21	1	50	12.9	38.8
SA8.0	8.0	8.89	10.9	1	25	15.0	33.3
SA8.0A	8.0	8.89	8.93	1	25	13.6	36.7
SA8.5	8.5	9.44	11.5	1	10	15.9	31.4
SA8.5A	8.5	9.44	10.4	1	10	14.4	34.7
SA9.0	9.0	10.0	12.2	1	5	16.9	29.5
SA9.0A	9.0	10.0	11.1	1	5	15.4	32.5
SA10	10	11.1	13.6	1	3	18.8	26.6
SA10A	10	11.1	12.3	1	3	17.0	29.4
SA11	11	12.2	14.9	1	3	20.1	24.9
SA11A	11	12.2	13.5	1	3	18.2	27.4
SA12	12	13.3	16.3	1	3	22.0	22.7
SA12A	12	13.3	14.7	1	3	19.9	25.1
SA13	13	14.4	17.6	1	3	23.8	21.0
SA13A	13	14.4	15.9	1	3	21.5	23.2
SA14	14	15.6	19.1	1	3	25.8	19.4
SA14A	14	15.6	17.2	1	3	23.2	21.5

\* = Add "C" or "CA" suffix for bidirectional device types. (SA5.0A is not available in Bi-Directional)

+ = For Bidirectional Types Having Vwm ≤ 10V, their Id limit is doubled.

# = See General Information for Impulse Current Waveform.

**TVS Diodes - 500 Watt Specifications - Electrical Characteristics - (Continued)**

Part Number*	Rated Standoff Voltage V <sub>wm</sub> (Volts)	Breakdown Voltage			Maximum Stand By Current @V <sub>wm</sub> + I <sub>d</sub> ( $\mu$ A)	10/1000 $\mu$ s Maximum Clamping Voltage @I <sub>ppm</sub> # V <sub>c</sub> Max (Volts)	10/1000 $\mu$ s Rated Peak Impulse Current I <sub>ppm</sub> # (Amperes)
		Min	Max	@I <sub>t</sub> (mA)			
SA15	15	16.7	20.4	1	3	26.9	18.8
SA15A	15	16.7	18.5	1	3	24.4	20.6
SA16	16	17.8	21.8	1	3	28.8	17.6
SA16A	16	17.8	19.7	1	3	26.0	19.2
SA17	17	18.9	23.1	1	3	30.5	16.4
SA17A	17	18.9	20.9	1	3	27.6	18.1
SA18	18	20.0	24.4	1	3	32.2	15.5
SA18A	18	20.0	22.1	1	3	29.2	17.2
SA20	20	22.2	27.1	1	3	35.8	13.9
SA20A	20	22.2	24.5	1	3	32.4	15.4
SA22	22	24.4	29.8	1	3	39.4	12.7
SA22A	22	24.4	26.9	1	3	35.5	14.1
SA24	24	26.7	32.6	1	3	43.0	11.6
SA24A	24	26.7	29.5	1	3	38.9	12.8
SA26	26	28.9	35.3	1	3	46.6	10.7
SA26A	26	28.9	31.9	1	3	42.1	11.9
SA28	28	31.1	38.0	1	3	50.0	9.9
SA28A	28	31.1	34.4	1	3	45.4	11.0
SA30	30	33.3	40.7	1	3	53.5	9.3
SA30A	30	33.3	36.8	1	3	48.4	10.3
SA33	33	36.7	44.9	1	3	59.0	8.5
SA33A	33	36.7	40.6	1	3	53.3	9.4
SA36	36	40.0	48.9	1	3	64.3	7.8
SA36A	36	40.0	44.2	1	3	58.1	8.6
SA40	40	44.4	54.3	1	3	71.4	7.0
SA40A	40	44.4	49.1	1	3	64.5	7.8

\* = Add "C" or "CA" suffix for bidirectional device types.

+ = For Bidirectional Types Having V<sub>wm</sub> <= 10V, their I<sub>d</sub> limit is doubled.

# = See General Information for Impulse Current Waveform.

**TVS Diodes - 500 Watt Specifications - Electrical Characteristics - (Continued)**

Part Number*	Rated Standoff Voltage Vwm (Volts)	Breakdown Voltage		Maximum Stand By Current @Vwm+ Id (mA)	Maximum Stand By Current @Vwm+ Id (μA)	10/1000μs Maximum Clamping Voltage @Ippm# Vc Max (Volts)	10/1000μs Rated Peak Impulse Current Ippm# (Amperes)
		Min	Max				
SA43	43	47.8	58.4	1	3	76.7	6.5
SA43A	43	47.8	52.8	1	3	69.4	7.2
SA45	45	50.0	61.1	1	3	80.3	6.2
SA45A	45	50.0	55.3	1	3	72.7	6.9
SA48	48	53.3	65.1	1	3	85.5	5.8
SA48A	48	53.3	58.9	1	3	77.4	6.5
SA51	51	56.7	69.3	1	3	91.1	5.5
SA51A	51	56.7	62.7	1	3	82.4	6.1
SA54	54	60.0	73.3	1	3	96.3	5.2
SA54A	54	60.0	66.3	1	3	87.1	5.7
SA58	58	64.4	78.7	1	3	103.0	4.9
SA58A	58	64.4	71.2	1	3	93.6	5.3
SA60	60	66.7	81.5	1	3	107.0	4.7
SA60A	60	66.7	73.7	1	3	96.8	5.2
SA64	64	71.1	86.9	1	3	114.0	4.4
SA64A	64	71.1	78.6	1	3	103.0	4.9
SA70	70	77.8	95.1	1	3	125.0	4.0
SA70A	70	77.8	86.0	1	3	113.0	4.4
SA75	75	83.3	102.0	1	3	134.0	3.7
SA75A	75	83.3	92.1	1	3	121.0	4.1
SA78	78	86.7	106.0	1	3	139.0	3.6
SA78A	78	86.7	95.8	1	3	126.0	4.0
SA85	85	94.4	115.0	1	3	151.0	3.3
SA85A	85	94.4	104.0	1	3	137.0	3.6
SA90	90	100	122.0	1	3	160.0	3.1
SA90A	90	100	111.0	1	3	146.0	3.4

\* = Add "C" or "CA" suffix for bidirectional device types.

+ = For Bidirectional Types Having Vwm ≤ 10V, their Id limit is doubled.

# = See General Information for Impulse Current Waveform.

**TVS Diodes - 500 Watt Specifications - Electrical Characteristics - (Continued)**

Part Number*	Rated Standoff Voltage	Breakdown Voltage			Maximum Stand By Current @Vwm+ Id	10/1000 $\mu$ s Maximum Clamping Voltage @Ippm# Vc Max	10/1000 $\mu$ s Rated Peak Impulse Current Ippm#
		Vbr (Volts)	Max	@It			
	Vwm (Volts)	Min	Max	(mA)	( $\mu$ A)	(Volts)	(Amperes)
SA100	100	111	136.0	1	3	179.9	2.8
SA100A	100	111	123.0	1	3	162.0	3.1
SA110	110	122	149.0	1	3	196.0	2.6
SA110A	110	122	135.0	1	3	177.0	2.8
SA120	120	133	163.0	1	3	214.0	2.3
SA120A	120	133	147.0	1	3	193.0	2.0
SA130	130	144	176.0	1	3	231.0	2.2
SA130A	130	144	159.0	1	3	209.0	2.4
SA150	150	167	204.0	1	3	268.0	1.9
SA150A	150	167	185.0	1	3	243.0	2.1
SA160	160	178	218.0	1	3	287.0	1.7
SA160A	160	178	197.0	1	3	259.0	1.9
SA170	170	189	231.0	1	3	304.0	1.6
SA170A	170	189	209.0	1	3	275.0	1.8

\* = Add "C" or "CA" suffix for bidirectional device types.

+ = For Bidirectional Types Having Vwm  $\leq$  10V, their Id limit is doubled.

# = See General Information for Impulse Current Waveform.

## TVS Diodes - 500 Watt Specifications - SA Series Features

### SA Series Features

- 500 watt peak pulse power dissipation
- Available in voltages from 5.0V to 170V
- Unidirectional and Bidirectional
- Glass passivated junction
- Low clamping factor
- Available in bulk or tape and reel (Reel quantity = 5,000 pieces)
- Each device 100% surge tested

### Absolute Maximum Ratings

- Peak pulse power dissipation (P<sub>ppm</sub>) at 25°C..... 500W
- Steady state power dissipation at lead temperature = 75°C (Lead length 3/8" min.)..... 1W
- Operating and storage temperatures..... -55°C to + 175°C

### Mechanical Dimensions

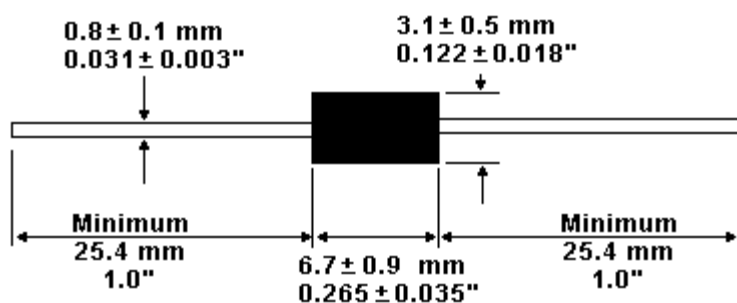

**TVS Diodes - 600 Watt Specifications - Electrical Characteristics**

Part Number*	Rated Standoff Voltage Vwm (Volts)	Breakdown Voltage			Maximum Stand By Current @Vwm+ Id (µA)	10/1000µs Maximum Clamping Voltage @Ippm# Vc Max (Volts)	10/1000µs Rated Peak Impulse Current Ippm# (Amperes)
		Vbr (Volts) Min	Max	@It (mA)			
P6KE6.8	5.50	6.12	7.48	10	1000	10.8	56
P6KE6.8A	5.80	6.45	7.14	10	1000	10.5	57
P6KE7.5	6.05	6.75	8.25	10	500	11.7	51
P6KE7.5A	6.40	7.13	7.88	10	500	11.3	53
P6KE8.2	6.63	7.38	9.02	10	200	12.5	48
P6KE8.2A	7.02	7.79	8.61	10	200	12.1	50
P6KE9.1	7.37	8.19	10.0	1	50	13.8	44
P6KE9.1A	7.78	8.65	9.55	1	50	13.4	45
P6KE10	8.10	9.00	11.0	1	10	15.0	40
P6KE10A	8.55	9.5	10.5	1	10	14.5	41
P6KE11	8.92	9.9	12.1	1	5	16.2	37
P6KE11A	9.40	10.5	11.6	1	5	15.6	38
P6KE12	9.72	10.8	13.2	1	5	17.3	35
P6KE12A	10.2	11.4	12.6	1	5	16.7	36
P6KE13	10.5	11.7	14.3	1	5	19.0	32
P6KE13A	11.1	12.4	13.7	1	5	18.2	33
P6KE15	12.1	13.5	16.5	1	5	22.0	27
P6KE15A	12.8	14.3	15.8	1	5	21.2	28
P6KE16	12.9	14.4	17.6	1	5	23.5	26
P6KE16A	13.6	15.2	16.8	1	5	22.5	27
P6KE18	14.5	16.2	19.8	1	5	26.5	23
P6KE18A	15.3	17.1	18.9	1	5	25.2	24
P6KE20	16.2	18.0	22.0	1	5	29.1	21
P6KE20A	17.1	19.0	21.0	1	5	27.7	22
P6KE22	17.8	19.8	24.2	1	5	31.9	19
P6KE22A	18.8	20.9	23.1	1	5	30.6	20

\* = Add "C" or "CA" suffix for bidirectional device types.

+ = For Bidirectional Types Having Vwm ≤ 10V, their Id limit is doubled.

# = See General Information for Impulse Current Waveform.



**TVS Diodes - 600 Watt Specifications - Electrical Characteristics - (Continued)**

Part Number*	Rated Standoff Voltage Vwm (Volts)	Breakdown Voltage			Maximum Stand By Current @Vwm+ Id (μA)	10/1000μs Maximum Clamping Voltage @Ippm# Vc Max (Volts)	10/1000μs Rated Peak Impulse Current Ippm# (Amperes)
		Vbr (Volts) Min	Max	@It (mA)			
P6KE24	19.4	21.6	26.4	1	5	34.7	17
P6KE24A	20.5	22.8	25.2	1	5	33.2	18
P6KE27	21.8	24.3	29.7	1	5	39.1	15
P6KE27A	23.1	25.7	28.4	1	5	37.5	16
P6KE30	24.3	27.0	33.0	1	5	43.5	14
P6KE30A	25.6	28.5	31.5	1	5	41.4	14.4
P6KE33	26.8	29.7	36.3	1	5	47.7	12.6
P6KE33A	28.2	31.4	34.7	1	5	45.7	13.2
P6KE36	29.1	32.4	39.6	1	5	52.0	11.6
P6KE36A	30.8	34.2	37.8	1	5	49.9	12.0
P6KE39	31.6	35.1	42.9	1	5	56.4	10.5
P6KE39A	33.3	37.1	41.0	1	5	53.9	11.2
P6KE43	34.8	38.7	47.3	1	5	61.9	9.6
P6KE43A	36.8	40.9	45.2	1	5	59.3	10.1
P6KE47	38.1	42.3	51.7	1	5	67.8	8.9
P6KE47A	40.2	44.7	49.4	1	5	64.8	9.3
P6KE51	41.3	45.9	56.1	1	5	73.5	8.2
P6KE51A	43.6	48.5	53.6	1	5	70.1	8.6
P6KE56	45.4	50.4	61.6	1	5	80.5	7.4
P6KE56A	47.8	53.2	58.8	1	5	77.0	7.8
P6KE62	50.2	55.8	68.2	1	5	89.0	6.8
P6KE62A	53.0	58.9	65.1	1	5	85.0	7.1
P6KE68	55.1	61.2	74.8	1	5	98.0	6.1
P6KE68A	58.1	64.6	71.4	1	5	92.0	6.5
P6KE75	60.7	67.5	82.5	1	5	108.0	5.5
P6KE75A	64.1	71.3	78.8	1	5	103.0	5.8

\* = Add "C" or "CA" suffix for bidirectional device types.

+ = For Bidirectional Types Having Vwm ≤ 10V, their Id limit is doubled.

# = See General Information for Impulse Current Waveform.

**TVS Diodes - 600 Watt Specifications - Electrical Characteristics - (Continued)**

Part Number*	Rated Standoff Voltage V <sub>wm</sub> (Volts)	Breakdown Voltage			Maximum Stand By Current @V <sub>wm</sub> + I <sub>d</sub> (μA)	10/1000μs Maximum Clamping Voltage @I <sub>ppm</sub> # V <sub>c</sub> Max (Volts)	10/1000μs Rated Peak Impulse Current I <sub>ppm</sub> # (Amperes)
		Min	Max	@I <sub>t</sub> (mA)			
P6KE82	66.4	73.8	90.2	1	5	118.0	5.1
P6KE82A	70.1	77.9	86.1	1	5	113.0	5.3
P6KE91	73.7	81.9	100.0	1	5	131.0	4.5
P6KE91A	77.8	86.5	95.5	1	5	125.0	4.8
P6KE100	81.0	90.0	110.0	1	5	144.0	4.2
P6KE100A	85.5	95.0	105.0	1	5	137.0	4.4
P6KE110	89.2	99.0	121.0	1	5	158.0	3.8
P6KE110A	94.0	105.0	116.0	1	5	152.0	4.0
P6KE120	97.2	108.0	132.0	1	5	173.0	3.5
P6KE120A	102.0	114.0	126.0	1	5	165.0	3.6
P6KE130	105.0	117.0	143.0	1	5	187.0	3.2
P6KE130A	111.0	124.0	137.0	1	5	179.0	3.3
P6KE150	121.0	135.0	165.0	1	5	215.0	2.8
P6KE150A	128.0	143.0	158.0	1	5	207.0	2.9
P6KE160	130.0	144.0	176.0	1	5	230.0	2.6
P6KE160A	136.0	152.0	168.0	1	5	219.0	2.7
P6KE170	138.0	153.0	187.0	1	5	244.0	2.5
P6KE170A	145.0	162.0	179.0	1	5	234.0	2.6
P6KE180	146.0	162.0	198.0	1	5	258.0	2.3
P6KE180A	154.0	171.0	189.0	1	5	246.0	2.4
P6KE200	162.0	180.0	220.0	1	5	287.0	2.1
P6KE200A	171.0	190.0	210.0	1	5	274.0	2.2
P6KE220	175.0	198.0	242.0	1	5	344.0	1.75
P6KE220A	185.0	209.0	231.0	1	5	328.0	1.83
P6KE250	202.0	225.0	275.0	1	5	360.0	1.67
P6KE250A	214.0	237.0	263.0	1	5	344.0	1.75

\* = Add "C" or "CA" suffix for bidirectional device types.

+ = For Bidirectional Types Having V<sub>wm</sub> ≤ 10V, their I<sub>d</sub> limit is doubled.

# = See General Information for Impulse Current Waveform.

**TVS Diodes - 600 Watt Specifications - Electrical Characteristics - (Continued)**

Part Number*	Rated Standoff Voltage	Breakdown Voltage			Maximum Stand By Current @Vwm+ Id	10/1000 $\mu$ s Maximum Clamping Voltage @Ippm# Vc Max	10/1000 $\mu$ s Rated Peak Impulse Current Ippm#
		Vbr (Volts)		@It			
	Vwm (Volts)	Min	Max	(mA)	( $\mu$ A)	(Volts)	(Amperes)
P6KE300	243.0	270.0	330.0	1	5	430.0	1.40
P6KE300A	256.0	285.0	315.0	1	5	414.0	1.45
P6KE350	284.0	315.0	385.0	1	5	504.0	1.20
P6KE350A	300.0	332.0	368.0	1	5	482.0	1.25
P6KE400	324.0	360.0	440.0	1	5	574.0	1.05
P6KE400A	342.0	380.0	420.0	1	5	548.0	1.10
P6KE440	356.0	396.0	484.0	1	5	631.0	0.99
P6KE440A	376.0	418.0	462.0	1	5	600.0	1.04
P6KE550	445.5	495.0	605.0	1	5	792.0	0.76
P6KE550A	467.5	522.5	577.5	1	5	753.5	0.80

\* = Add "C" or "CA" suffix for bidirectional device types.

+ = For Bidirectional Types Having Vwm  $\leq$  10V, their Id limit is doubled.

# = See General Information for Impulse Current Waveform.

## TVS Diodes - 600 Watt Specifications - P6KE Series Features

### P6KE Series Features

- 600 watt peak pulse power dissipation
- Available in voltages from 6.8V to 400V
- Unidirectional and Bidirectional
- Glass passivated junction
- Low clamping factor
- Available in bulk or tape and reel (Reel quantity = 5,000 pieces)
- Each device 100% surge tested

### Absolute Maximum Ratings

- Peak pulse power dissipation (Pppm) at 25°C..... 600W
- Steady state power dissipation at lead temperature = 75°C (Lead length 3/8" min.)..... 5W
- Operating and storage temperatures..... -55°C to + 175°C

### Mechanical Dimensions

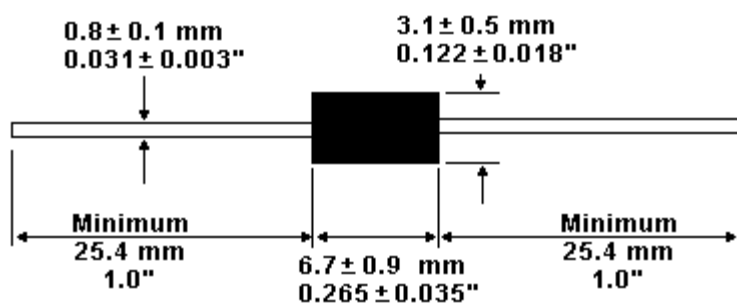

**TVS Diodes - 1500 Watt Specifications - 1.5KE Series Electrical Characteristics**

Part Number*	Rated Standoff Voltage V <sub>wm</sub> (Volts)	Breakdown Voltage			Maximum Stand By Current @V <sub>wm</sub> + I <sub>d</sub> ( $\mu$ A)	10/1000 $\mu$ s Maximum Clamping Voltage @I <sub>ppm</sub> # V <sub>c</sub> Max (Volts)	10/1000 $\mu$ s Rated Peak Impulse Current I <sub>ppm</sub> # (Amperes)
		V <sub>br</sub> (Volts)	Min	Max			
1.5KE6.8	5.50	6.12	7.48	10	1000	10.8	139.0
1.5KE6.8A	5.80	6.45	7.14	10	1000	10.5	143.0
1.5KE7.5	6.05	6.75	8.25	10	500	11.7	128.0
1.5KE7.5A	6.40	7.13	7.88	10	500	11.3	132.0
1.5KE8.2	6.63	7.38	9.02	10	200	12.5	120.0
1.5KE8.2A	7.02	7.79	8.61	10	200	12.1	124.0
1.5KE9.1	7.37	8.19	10.0	1	50	13.8	109.0
1.5KE9.1A	7.78	8.65	9.55	1	50	13.4	112.0
1.5KE10	8.10	9.00	11.0	1	10	15.0	100.0
1.5KE10A	8.55	9.5	10.5	1	10	14.5	103.0
1.5KE11	8.92	9.9	12.1	1	5	16.2	93.0
1.5KE11A	9.40	10.5	11.6	1	5	15.6	96.0
1.5KE12	9.72	10.8	13.2	1	5	17.3	87.0
1.5KE12A	10.2	11.4	12.6	1	5	16.7	90.0
1.5KE13	10.5	11.7	14.3	1	5	19.0	79.0
1.5KE13A	11.1	12.4	13.7	1	5	18.2	82.0
1.5KE15	12.1	13.5	16.5	1	5	22.0	68.0
1.5KE15A	12.8	14.3	15.8	1	5	21.2	71.0
1.5KE16	12.9	14.4	17.6	1	5	23.5	64.0
1.5KE16A	13.6	15.2	16.8	1	5	22.5	67.0
1.5KE18	14.5	16.2	19.8	1	5	26.5	56.5
1.5KE18A	15.3	17.1	18.9	1	5	25.2	59.5
1.5KE20	16.2	18.0	22.0	1	5	29.1	51.5
1.5KE20A	17.1	19.0	21.0	1	5	27.7	54.0
1.5KE22	17.8	19.8	24.2	1	5	31.9	47.0
1.5KE22A	18.8	20.9	23.1	1	5	30.6	49.0

Metal hermetically sealed (DO13) version of this diode is available upon request.

\* = Add "C" or "CA" suffix for bidirectional device types.

+ = For Bidirectional Types Having V<sub>wm</sub> <= 10V, their I<sub>d</sub> limit is doubled.

# = See General Information for Impulse Current Waveform.

**TVS Diodes - 1500 Watt Specifications - 1.5KE Series Electrical Characteristics - (Continued)**

Part Number*	Rated Standoff Voltage Vwm (Volts)	Breakdown Voltage			Maximum Stand By Current @Vwm+ Id (µA)	10/1000µs Maximum Clamping Voltage @Ippm# Vc Max (Volts)	10/1000µs Rated Peak Impulse Current Ippm# (Amperes)
		Vbr (Volts)	Min	Max			
1.5KE24	19.4	21.6	26.4	1	5	34.7	43.0
1.5KE24A	20.5	22.8	25.2	1	5	33.2	45.0
1.5KE27	21.8	24.3	29.7	1	5	39.1	38.5
1.5KE27A	23.1	25.7	28.4	1	5	37.5	40.0
1.5KE30	24.3	27.0	33.0	1	5	43.5	34.5
1.5KE30A	25.6	28.5	31.5	1	5	41.4	36.0
1.5KE33	26.8	29.7	36.3	1	5	47.7	31.5
1.5KE33A	28.2	31.4	34.7	1	5	45.7	33.0
1.5KE36	29.1	32.4	39.6	1	5	52.0	29.0
1.5KE36A	30.8	34.2	37.8	1	5	49.9	30.0
1.5KE39	31.6	35.1	42.9	1	5	56.4	26.5
1.5KE39A	33.3	37.1	41.0	1	5	53.9	28.0
1.5KE43	34.8	38.7	47.3	1	5	61.9	24.0
1.5KE43A	36.8	40.9	45.2	1	5	59.3	25.3
1.5KE47	38.1	42.3	51.7	1	5	67.8	22.2
1.5KE47A	40.2	44.7	49.4	1	5	64.8	23.2
1.5KE51	41.3	45.9	56.1	1	5	73.5	20.4
1.5KE51A	43.6	48.5	53.6	1	5	70.1	21.4
1.5KE56	45.4	50.4	61.6	1	5	80.5	18.6
1.5KE56A	47.8	53.2	58.8	1	5	77.0	19.5
1.5KE62	50.2	55.8	68.2	1	5	89.0	16.9
1.5KE62A	53.0	58.9	65.1	1	5	85.0	17.7
1.5KE68	55.1	61.2	74.8	1	5	98.0	15.3
1.5KE68A	58.1	64.6	71.4	1	5	92.0	16.3
1.5KE75	60.7	67.5	82.5	1	5	108.0	13.9
1.5KE75A	64.1	71.3	78.8	1	5	103.0	14.6

Metal hermetically sealed (DO13) version of this diode is available upon request.

\* = Add "C" or "CA" suffix for bidirectional device types.

+ = For Bidirectional Types Having Vwm ≤ 10V, their Id limit is doubled.

# = See General Information for Impulse Current Waveform.

**TVS Diodes - 1500 Watt Specifications - 1.5KE Series Electrical Characteristics - (Continued)**

Part Number*	Rated Standoff Voltage V <sub>wm</sub> (Volts)	Breakdown Voltage			Maximum Stand By Current @V <sub>wm</sub> + I <sub>d</sub> (μA)	10/1000μs Maximum Clamping Voltage @I <sub>ppm</sub> # V <sub>c</sub> Max (Volts)	10/1000μs Rated Peak Impulse Current I <sub>ppm</sub> # (Amperes)
		V <sub>br</sub> (Volts)	Min	Max			
1.5KE82	66.4	73.8	90.2	1	5	118.0	12.7
1.5KE82A	70.1	77.9	86.1	1	5	113.0	13.3
1.5KE91	73.7	81.9	100.0	1	5	131.0	11.4
1.5KE91A	77.8	86.5	95.5	1	5	125.0	12.0
1.5KE100	81.0	90.0	110.0	1	5	144.0	10.4
1.5KE100A	85.5	95.0	105.0	1	5	137.0	11.0
1.5KE110	89.2	99.0	121.0	1	5	158.0	9.5
1.5KE110A	94.0	105.0	116.0	1	5	152.0	9.9
1.5KE120	97.2	108.0	132.0	1	5	173.0	8.7
1.5KE120A	102.0	114.0	126.0	1	5	165.0	9.1
1.5KE130	105.0	117.0	143.0	1	5	187.0	8.0
1.5KE130A	111.0	124.0	137.0	1	5	179.0	8.4
1.5KE150	121.0	135.0	165.0	1	5	215.0	7.0
1.5KE150A	128.0	143.0	158.0	1	5	207.0	7.2
1.5KE160	130.0	144.0	176.0	1	5	230.0	6.5
1.5KE160A	136.0	152.0	168.0	1	5	219.0	6.8
1.5KE170	138.0	153.0	187.0	1	5	244.0	6.2
1.5KE170A	145.0	162.0	179.0	1	5	234.0	6.4
1.5KE180	146.0	162.0	198.0	1	5	258.0	5.8
1.5KE180A	154.0	171.0	189.0	1	5	246.0	6.1
1.5KE200	162.0	180.0	220.0	1	5	287.0	5.2
1.5KE200A	171.0	190.0	210.0	1	5	274.0	5.5
1.5KE220	175.0	198.0	242.0	1	5	344.0	4.3
1.5KE220A	185.0	209.0	231.0	1	5	328.0	4.6
1.5KE250	202.0	225.0	275.0	1	5	360.0	5.0
1.5KE250A	214.0	237.0	263.0	1	5	344.0	5.0

Metal hermetically sealed (DO13) version of this diode is available upon request.

\* = Add "C" or "CA" suffix for bidirectional device types.

+ = For Bidirectional Types Having V<sub>wm</sub> ≤ 10V, their I<sub>d</sub> limit is doubled.

# = See General Information for Impulse Current Waveform.

**TVS Diodes - 1500 Watt Specifications - 1.5KE Series Electrical Characteristics - (Continued)**

Part Number*	Rated Standoff Voltage	Breakdown Voltage			Maximum Stand By Current @Vwm+ Id	10/1000 $\mu$ s Maximum Clamping Voltage @Ippm# Vc Max	10/1000 $\mu$ s Rated Peak Impulse Current Ippm#
		Vbr (Volts)		@It			
	Vwm (Volts)	Min	Max	(mA)	( $\mu$ A)	(Volts)	(Amperes)
1.5KE300	243.0	270.0	330.0	1	5	430.0	5.0
1.5KE300A	256.0	285.0	315.0	1	5	414.0	5.0
1.5KE350	284.0	315.0	385.0	1	5	504.0	4.0
1.5KE350A	300.0	360.0	440.0	1	5	574.0	4.0
1.5KE400	324.0	360.0	440.0	1	5	574.0	4.0
1.5KE400A	342.0	380.0	420.0	1	5	548.0	4.0
1.5KE440	356.0	396.0	484.0	1	5	631.0	2.4
1.5KE440A	376.0	418.0	462.0	1	5	600.0	2.6

Metal hermetically sealed (DO13) version of this diode is available upon request.

\* = Add "C" or "CA" suffix for bidirectional device types.

+ = For Bidirectional Types Having Vwm  $\leq$  10V, their Id limit is doubled.

# = See General Information for Impulse Current Waveform.



## TVS Diodes - 1500 Watt Specifications - 1.5KE Series Features

### 1.5KE Series Features

- 1500 watt peak pulse power dissipation
- Available in voltages from 6.8V to 400V
- Unidirectional and Bidirectional
- Glass passivated junction
- Low clamping factor
- Available in bulk or tape and reel (Reel quantity = 1,500 pieces)
- Each device 100% surge tested
- Metal hermetically sealed (DO13) version of this diode is available upon request.

### Absolute Maximum Ratings

- Peak pulse power dissipation (Pppm) at 25°C..... 1500W
- Steady state power dissipation at lead temperature = 75°C (Lead length 3/8" min.)..... 5W
- Operating and storage temperatures..... -55°C to + 175°C

### Mechanical Dimensions

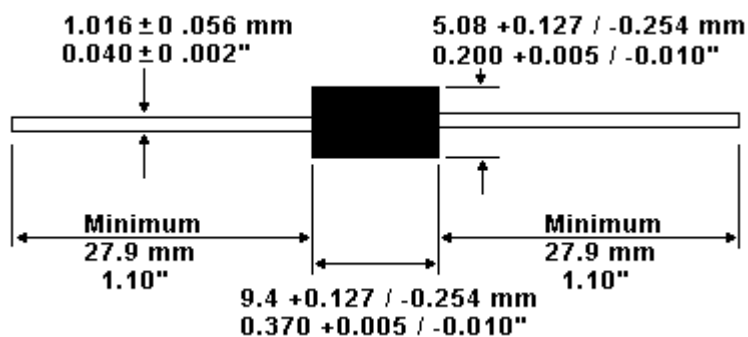

**TVS Diodes - 3000 Watt Specifications - 3KP Series Electrical Characteristics**

Part Number*	Rated Standoff Voltage Vwm (Volts)	Breakdown Voltage			Maximum Stand By Current @Vwm+ Id ( $\mu$ A)	10/1000 $\mu$ s Maximum Clamping Voltage @Ippm# Vc Max (Volts)	10/1000 $\mu$ s Rated Peak Impulse Current Ippm# (Amperes)
		Vbr (Volts)		@It (mA)			
	Min	Max					
3KP5.0	5.00	6.40	7.55	10	1000	9.6	312.5
3KP5.0A	5.00	6.40	7.25	10	1000	9.2	326.0
3KP6.0	6.00	6.67	8.45	10	1000	11.4	263.2
3KP6.0A	6.00	6.67	7.67	10	1000	10.3	291.3
3KP6.5	6.50	7.22	9.14	10	500	12.3	243.9
3KP6.5A	6.50	7.22	8.30	10	500	11.2	267.9
3KP7.0	7.00	7.78	9.86	10	200	13.3	225.6
3KP7.0A	7.00	7.78	8.95	10	200	12.0	250.0
3KP7.5	7.50	8.33	10.67	1	100	14.3	209.8
3KP7.5A	7.50	8.33	9.58	1	100	12.9	232.6
3KP8.0	8.00	8.89	11.30	1	50	15.0	220.0
3KP8.0A	8.00	8.89	10.23	1	50	13.6	220.6
3KP8.5	8.50	9.44	11.92	1	25	15.9	188.8
3KP8.5A	8.50	9.44	10.82	1	25	14.4	208.4
3KP9.0	9.00	10.00	12.60	1	10	16.9	177.4
3KP9.0A	9.00	10.00	11.50	1	10	15.4	194.8
3KP10	10.00	11.10	14.10	1	5	18.8	159.6
3KP10A	10.00	11.10	12.80	1	5	17.0	176.4
3KP11	11.00	12.20	15.40	1	5	20.1	149.2
3KP11A	11.00	12.20	14.00	1	5	18.2	184.8
3KP12	12.00	13.30	16.90	1	5	22.0	136.4
3KP12A	12.00	13.30	15.30	1	5	19.9	150.6
3KP13	13.00	14.40	18.20	1	5	23.8	126.0
3KP13A	13.00	14.40	16.50	1	5	21.5	139.4
3KP14	14.00	15.60	19.80	1	5	25.8	116.2
3KP14A	14.00	15.60	17.90	1	5	23.2	129.4
3KP15	15.00	16.70	21.10	1	5	26.9	111.6
3KP15A	15.00	16.70	19.20	1	5	24.4	123.0

Add "C" or "CA" suffix for bidirectional device types.

+ = For Bidirectional Types Having Vwm  $\leq$  10V, their Id limit is doubled.

# = See General Information for Impulse Current Waveform.

**TVS Diodes - 3000 Watt Specifications - 3KP Series Electrical Characteristics - (Continued)**

Part Number*	Rated Standoff Voltage V <sub>wm</sub>  (Volts)	Breakdown Voltage			Maximum Stand By Current @V <sub>wm</sub> + I <sub>d</sub>  ( $\mu$ A)	10/1000 $\mu$ s Maximum Clamping Voltage @I <sub>ppm</sub> # V <sub>c</sub> Max  (Volts)	10/1000 $\mu$ s Rated Peak Impulse Current I <sub>ppm</sub> #  (Amperes)
		V <sub>br</sub> (Volts)		@I <sub>t</sub>			
	Min	Max	(mA)				
3KP16	16.00	17.80	22.60	1	5	28.8	104.2
3KP16A	16.00	17.80	20.50	1	5	26.0	115.4
3KP17	17.00	18.90	23.90	1	5	30.5	98.4
3KP17A	17.00	18.90	21.70	1	5	27.6	106.6
3KP18	18.00	20.00	25.30	1	5	32.2	93.2
3KP18A	18.00	20.00	23.30	1	5	29.2	102.8
3KP20	20.00	22.20	28.10	1	5	35.8	83.8
3KP20A	20.00	22.20	25.50	1	5	32.4	92.6
3KP22	22.00	24.40	30.90	1	5	39.4	76.2
3KP22A	22.00	24.40	28.00	1	5	35.5	84.4
3KP24	24.00	26.70	33.80	1	5	43.0	69.8
3KP24A	24.00	26.70	30.70	1	5	38.9	77.2
3KP26	26.00	28.90	36.60	1	5	46.6	64.4
3KP26A	26.00	28.90	33.20	1	5	42.1	71.2
3KP28	28.00	31.10	39.40	1	5	50.0	60.0
3KP28A	28.00	31.10	35.80	1	5	45.4	66.0
3KP30	30.00	33.30	42.20	1	5	53.5	56.0
3KP30A	30.00	33.30	38.30	1	5	48.4	62.0
3KP33	33.00	36.70	46.50	1	5	59.0	50.4
3KP33A	33.00	36.70	42.20	1	5	53.3	56.2
3KP36	36.00	40.00	50.70	1	5	64.3	46.6
3KP36A	36.00	40.00	46.00	1	5	58.1	51.6
3KP40	40.00	44.40	53.30	1	5	71.4	42.0
3KP40A	40.00	44.40	51.10	1	5	64.5	46.4
3KP43	43.00	47.80	60.50	1	5	76.7	39.2
3KP43A	43.00	47.80	54.90	1	5	69.4	43.2
3KP45	45.00	50.00	63.30	1	5	80.3	37.4
3KP45A	45.00	50.00	57.50	1	5	72.7	41.2

Add "C" or "CA" suffix for bidirectional device types.

+ = For Bidirectional Types Having V<sub>wm</sub> <= 10V, their I<sub>d</sub> limit is doubled.

# = See General Information for Impulse Current Waveform.

**TVS Diodes - 3000 Watt Specifications - 3KP Series Electrical Characteristics - (Continued)**

Part Number*	Rated Standoff Voltage Vwm (Volts)	Breakdown Voltage			Maximum Stand By Current @Vwm+ Id (μA)	10/1000μs Maximum Clamping Voltage @Ippm# Vc Max (Volts)	10/1000μs Rated Peak Impulse Current Ippm# (Amperes)
		Vbr (Volts) Min	Max	@It (mA)			
3KP48	48.00	53.30	67.50	1	5	85.5	35.0
3KP48A	48.00	53.30	61.30	1	5	77.4	38.8
3KP51	51.00	56.70	71.80	1	5	91.1	37.0
3KP51A	51.00	56.70	65.20	1	5	82.4	36.4
3KP54	54.00	60.00	76.00	1	5	96.3	31.2
3KP54A	54.00	60.00	69.00	1	5	87.1	34.4
3KP58	58.00	64.40	81.60	1	5	103.0	29.2
3KP58A	58.00	64.40	74.10	1	5	93.6	32.0
3KP60	60.00	66.70	84.50	1	5	107.0	28.0
3KP60A	60.00	66.70	76.70	1	5	96.8	31.0
3KP64	64.00	71.10	90.10	1	5	114.0	26.4
3KP64A	64.00	71.10	81.80	1	5	103.0	29.2
3KP70	70.00	77.80	98.60	1	5	125.0	24.0
3KP70A	70.00	77.80	89.50	1	5	113.0	26.6
3KP75	75.00	83.30	105.70	1	5	134.0	22.4
3KP75A	75.00	83.30	98.80	1	5	121.0	24.8
3KP78	78.00	86.70	109.80	1	5	139.0	21.6
3KP78A	78.00	86.70	99.70	1	5	126.0	22.8
3KP85	85.00	94.40	119.20	1	5	151.0	19.8
3KP85A	85.00	94.40	108.20	1	5	137.0	20.8
3KP90	90.00	100.00	126.50	1	5	160.0	18.8
3KP90A	90.00	100.00	115.50	1	5	146.0	20.6
3KP100	100.00	111.00	141.00	1	5	179.0	16.6
3KP100A	100.00	111.00	128.00	1	5	162.0	18.6
3KP110	110.00	122.00	154.50	1	5	196.0	15.4
3KP110A	110.00	122.00	140.50	1	5	177.0	16.8
3KP120	120.00	133.00	169.00	1	5	214.0	14.0
3KP120A	120.00	133.00	153.00	1	5	193.0	15.6

Add "C" or "CA" suffix for bidirectional device types.

+ = For Bidirectional Types Having Vwm ≤ 10V, their Id limit is doubled.

# = See General Information for Impulse Current Waveform.

**TVS Diodes - 3000 Watt Specifications - 3KP Series Electrical Characteristics - (Continued)**

Part Number*	Rated Standoff Voltage Vwm (Volts)	Breakdown Voltage			Maximum Stand By Current @Vwm+ Id ( $\mu$ A)	10/1000 $\mu$ s Maximum Clamping Voltage @Ippm# Vc Max (Volts)	10/1000 $\mu$ s Rated Peak Impulse Current Ippm# (Amperes)
		Vbr (Volts) Min	@It Max	(mA)			
3KP130	130.00	144.00	182.50	1	5	231.0	13.0
3KP130A	130.00	144.00	165.50	1	5	209.0	14.4
3KP150	150.00	167.00	211.50	1	5	268.0	11.2
3KP150A	150.00	167.00	192.50	1	5	243.0	12.4
3KP160	160.00	178.00	226.00	1	5	287.0	10.4
3KP160A	160.00	178.00	205.00	1	5	259.0	11.6
3KP170	170.00	189.00	239.50	1	5	304.0	9.8
3KP170A	170.00	189.00	217.50	1	5	275.0	11.0

Add "C" or "CA" suffix for bidirectional device types.

+ = For Bidirectional Types Having Vwm  $\leq$  10V, their Id limit is doubled.

# = See General Information for Impulse Current Waveform.

## TVS Diodes - 3000 Watt - 3KP Series Features

### 3KP Series Features

- 3000 watt peak pulse power dissipation
- Available in voltages from 5.0V to 170V
- Unidirectional and Bidirectional
- Glass passivated junction
- Low clamping factor
- Available in bulk or tape and reel (Reel quantity = 800 pieces)
- Each device 100% surge tested

### Absolute Maximum Ratings

- Peak pulse power dissipation (Pppm) at 25°C..... 3000W
- Steady state power dissipation at lead temperature = 75°C (Lead length 3/8" min.)..... 8W
- Operating and storage temperatures..... -55°C to + 175°C
- UL497B, File # E135015

### Mechanical Dimensions

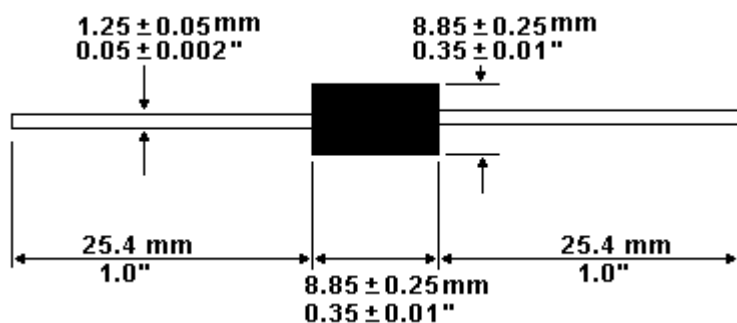

**TVS Diodes - 5000 Watt Specifications - 5KP Series Electrical Characteristics**

Part Number*	Rated Standoff Voltage Vwm (Volts)	Breakdown Voltage			Maximum Stand By Current @Vwm+ Id (µA)	10/1000µs Maximum Clamping Voltage @Ippm# Vc Max (Volts)	10/1000µs Rated Peak Impulse Current Ippm# (Amperes)	Temperature Coefficient of Vbr (mV/°C)
		Vbr (Volts)		@It (mA)				
		Min	Max					
%5KP5.0	5.0	6.40	7.30	50	5000	9.6	520.0	4.0
%5KP5.0A	5.0	6.40	7.00	50	5000	9.2	543.0	4.0
%5KP6.0	6.0	6.67	8.15	50	5000	11.4	439.0	4.0
%5KP6.0A	6.0	6.67	7.37	50	5000	10.3	485.0	4.0
5KP6.5	6.5	7.22	8.82	50	2000	12.3	407.0	4.0
5KP6.5A	6.5	7.22	7.98	50	2000	11.2	447.0	4.0
5KP7.0	7.0	7.78	9.51	50	1000	13.3	378.0	5.0
5KP7.0A	7.0	7.78	8.60	50	1000	12.0	417.0	5.0
5KP7.5	7.5	8.33	10.2	5.0	250	14.3	350.0	6.0
5KP7.5A	7.5	8.33	9.21	5.0	250	12.9	388.0	6.0
5KP8.0	8.0	8.89	10.9	5.0	150	15.0	333.0	6.0
5KP8.0A	8.0	8.89	9.83	5.0	150	13.6	367.0	6.0
5KP8.5	8.5	9.44	11.5	5.0	50	15.9	314.0	7.0
5KP8.5A	8.5	9.44	10.4	5.0	50	14.4	347.0	7.0
5KP9.0	9.0	10.0	12.2	5.0	20	16.9	295.0	8.0
5KP9.0A	9.0	10.0	11.1	5.0	20	15.4	325.0	8.0
5KP10	10.0	11.1	13.6	5.0	15	18.8	266.0	9.0
5KP10A	10.0	11.1	12.3	5.0	15	17.0	294.0	9.0
5KP11	11.0	12.2	14.9	5.0	10	20.1	249.0	10.0
5KP11A	11.0	12.2	13.5	5.0	10	18.2	274.0	10.0
5KP12	12.0	13.3	16.3	5.0	10	22.0	227.0	11.0
5KP12A	12.0	13.3	14.7	5.0	10	19.9	251.0	11.0
5KP13	13.0	14.4	17.6	5.0	10	23.8	210.0	12.0
5KP13A	13.0	14.4	15.9	5.0	10	21.5	232.0	12.0
5KP14	14.0	15.6	19.1	5.0	10	25.8	194.0	13.0
5KP14A	14.0	15.6	17.2	5.0	10	23.2	215.0	13.0

\* = Add "C" or "CA" suffix for bidirectional device types.

+ = For Bidirectional Types Having Vwm ≤ 10V, their Id limit is doubled.

# = See General Information for Impulse Current Waveform.

% = Only available in Uni-Polar.

**TVS Diodes - 5000 Watt Specifications - 5KP Series Electrical Characteristics - (Continued)**

Part Number*	Rated Standoff Voltage Vwm (Volts)	Breakdown Voltage			Maximum Stand By Current @Vwm+ Id (µA)	10/1000µs Maximum Clamping Voltage @Ippm# Vc Max (Volts)	10/1000µs Rated Peak Impulse Current Ippm# (Amperes)	Temperature Coefficient of Vbr (mV/°C)
		Vbr (Volts)		@It (mA)				
	Min	Max						
5KP15	15.0	16.7	20.4	5.0	10	26.9	188.0	15.0
5KP15A	15.0	16.7	18.5	5.0	10	24.4	206.0	15.0
5KP16	16.0	17.8	21.8	5.0	10	28.8	176.0	18.0
5KP16A	16.0	17.8	19.7	5.0	10	26.0	192.0	16.0
5KP17	17.0	18.9	23.1	5.0	10	30.5	164.0	19.0
5KP17A	17.0	18.9	20.9	5.0	10	27.6	181.0	18.0
5KP18	18.0	20.0	24.4	5.0	10	32.2	155.0	20.0
5KP18A	18.0	20.0	22.1	5.0	10	29.2	172.0	19.0
5KP20	20.0	22.2	27.1	5.0	10	35.8	139.0	24.0
5KP20A	20.0	22.2	24.5	5.0	10	32.4	154.0	22.0
5KP22	22.0	24.4	29.8	5.0	10	39.4	127.0	27.0
5KP22A	22.0	24.4	26.9	5.0	10	35.5	141.0	24.0
5KP24	24.0	26.7	32.6	5.0	10	43.0	116.0	30.0
5KP24A	24.0	26.7	29.5	5.0	10	38.9	128.0	27.0
5KP26	26.0	28.9	35.3	5.0	10	46.6	107.0	33.0
5KP26A	26.0	28.9	31.9	5.0	10	42.1	119.0	29.0
5KP28	28.0	31.1	39.0	5.0	10	50.1	99.0	34.0
5KP28A	28.0	31.1	34.4	5.0	10	45.5	110.0	30.0
5KP30	30.0	33.3	40.7	5.0	10	53.5	93.0	38.0
5KP30A	30.0	33.3	36.8	5.0	10	48.4	103.0	35.0
5KP33	33.0	36.7	44.9	5.0	10	59.0	85.0	41.0
5KP33A	33.0	36.7	40.6	5.0	10	53.3	94.0	38.0
5KP36	36.0	40.0	48.9	5.0	10	64.3	78.0	45.0
5KP36A	36.0	40.0	44.2	5.0	10	58.1	86.0	40.0
5KP40	40.0	44.4	54.3	5.0	10	71.4	70.0	50.0
5KP40A	40.0	44.4	49.1	5.0	10	64.5	78.0	45.0

\* = Add "C" or "CA" suffix for bidirectional device types.

+ = For Bidirectional Types Having Vwm ≤ 10V, their Id limit is doubled.

# = See General Information for Impulse Current Waveform.



**TVS Diodes - 5000 Watt Specifications - 5KP Series Electrical Characteristics - (Continued)**

Part Number*	Rated Standoff Voltage Vwm (Volts)	Breakdown Voltage			Maximum Stand By Current @Vwm+ Id ( $\mu$ A)	10/1000 $\mu$ s Maximum Clamping Voltage @Ippm# Vc Max (Volts)	10/1000 $\mu$ s Rated Peak Impulse Current Ippm# (Amperes)	Temperature Coefficient of Vbr (mV/ $^{\circ}$ C)
		Vbr (Volts)	@It					
	Min	Max	(mA)					
5KP43	43.0	47.8	58.4	5.0	10	76.7	65.0	54.0
5KP43A	43.0	47.8	52.8	5.0	10	69.4	72.0	49.0
5KP45	45.0	50.0	61.1	5.0	10	80.3	62.0	57.0
5KP45A	45.0	50.0	55.3	5.0	10	72.7	69.0	51.0
5KP48	48.0	53.3	65.2	5.0	10	85.5	58.0	62.0
5KP48A	48.0	53.3	58.9	5.0	10	77.4	65.0	55.0
5KP51	51.0	56.7	69.3	5.0	10	91.1	55.0	65.0
5KP51A	51.0	56.7	62.7	5.0	10	82.4	61.0	60.0
5KP54	54.0	60.0	73.3	5.0	10	96.3	52.0	70.0
5KP54A	54.0	60.0	66.3	5.0	10	87.1	57.0	64.0
5KP58	58.0	64.4	78.7	5.0	10	103.0	49.0	77.0
5KP58A	58.0	64.4	71.2	5.0	10	93.6	53.0	69.0
5KP60	60.0	66.7	81.5	5.0	10	107.0	47.0	79.0
5KP60A	60.0	66.7	73.7	5.0	10	96.8	52.0	70.0
5KP64	64.0	71.1	96.9	5.0	10	114.0	44.0	85.0
5KP64A	64.0	71.1	78.6	5.0	10	103.0	49.0	75.0
5KP70	70.0	77.6	95.1	5.0	10	125.0	40.0	93.0
5KP70A	70.0	77.6	86.0	5.0	10	113.0	44.0	84.0
5KP75	75.0	83.3	102.0	5.0	10	134.0	37.0	100.0
5KP75A	75.0	83.3	92.1	5.0	10	121.0	41.0	90.0
5KP78	78.0	86.7	106.0	5.0	10	139.0	36.0	104.0
5KP78A	78.0	86.7	95.8	5.0	10	126.0	40.0	94.0
5KP85	85.0	94.4	115.0	5.0	10	151.0	33.0	113.0
5KP85A	85.0	94.4	104.0	5.0	10	137.0	36.0	102.0
5KP90	90.0	100.0	122.0	5.0	10	160.0	31.0	120.0
5KP90A	90.0	100.0	111.0	5.0	10	146.0	34.0	109.0

\* = Add "C" or "CA" suffix for bidirectional device types.

+ = For Bidirectional Types Having Vwm  $\leq$  10V, their Id limit is doubled.

# = See General Information for Impulse Current Waveform.

**TVS Diodes - 5000 Watt Specifications - 5KP Series Electrical Characteristics - (Continued)**

Part Number*	Rated Standoff Voltage Vwm (Volts)	Breakdown Voltage			Maximum Stand By Current @Vwm+ Id ( $\mu$ A)	10/1000 $\mu$ s Maximum Clamping Voltage @Ippm# Vc Max (Volts)	10/1000 $\mu$ s Rated Peak Impulse Current Ippm# (Amperes)	Temperature Coefficient of Vbr (mV/ $^{\circ}$ C)
		Vbr (Volts)		@It				
		Min	Max	(mA)				
5KP100	100.0	111.0	136.0	5.0	10	179.0	28.0	134.0
5KP110	110.0	122.0	149.0	5.0	10	196.0	26.0	147.0
5KP120	120.0	133.0	163.0	5.0	10	215.0	23.0	158.0
5KP150	150.0	166.0	204.0	5.0	10	268.0	18.5	200.0
5KP180	180.0	200.0	244.0	5.0	10	320.0	15.0	240.0

\* = Add "C" or "CA" suffix for bidirectional device types.

+ = For Bidirectional Types Having Vwm  $\leq$  10V, their Id limit is doubled.

# = See General Information for Impulse Current Waveform.

## TVS Diodes - 5000 Watt - 5KP Series Features

### 5KP Series Features

- 5000 watt peak pulse power dissipation
- Available in voltages from 5.0V to 180V
- Unidirectional and Bidirectional
- Glass passivated junction
- Low clamping factor
- Available in bulk or tape and reel (Reel quantity = 1,000 pieces)
- Each device 100% surge tested

### Absolute Maximum Ratings

- Peak pulse power dissipation (P<sub>ppm</sub>) at 25°C..... 5000W
- Steady state power dissipation at lead temperature = 75°C (Lead length 3/8" min.)..... 8W
- Operating and storage temperatures..... -55°C to + 175°C

### Mechanical Dimensions

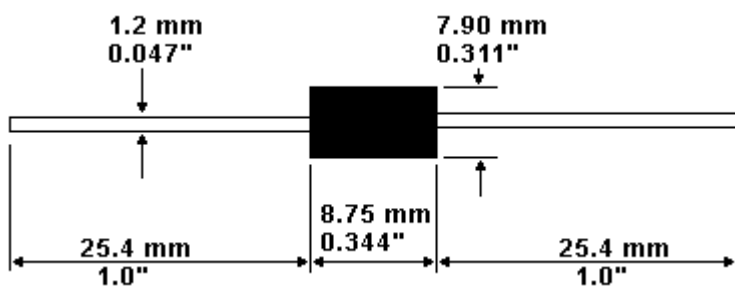

**TVS Diodes - 15000 Watt Specifications - 15KP Series Electrical Characteristics**

Part Number*	Rated Standoff Voltage V <sub>wm</sub> (Volts)	Breakdown Voltage		Maximum Stand By Current @V <sub>wm</sub> + I <sub>d</sub> ( $\mu$ A)	10/1000 $\mu$ s Maximum Clamping Voltage @I <sub>ppm</sub> # V <sub>c</sub> Max (Volts)	10/1000 $\mu$ s Rated Peak Impulse Current I <sub>ppm</sub> # (Amperes)
		V <sub>br</sub> (Volts) Min	@I <sub>t</sub> (mA)			
15KP17	17	18.9	50	5000	32.2	464.0
15KP17A	17	18.9	50	5000	29.3	512.0
15KP18	18	20.0	50	5000	34.2	439.0
15KP18A	18	20.0	50	5000	30.9	485.0
15KP20	20	22.2	20	1500	37.9	396.0
15KP20A	20	22.2	20	1500	34.3	437.0
15KP22	22	24.4	10	500	41.1	365.0
15KP22A	22	24.4	10	500	37.1	404.0
15KP24	24	26.7	5	150	45.0	333.0
15KP24A	24	26.7	5	150	40.7	369.0
15KP26	26	28.9	5	50	48.7	308.0
15KP26A	26	28.9	5	50	44.0	341.0
15KP28	28	31.1	5	25	52.4	286.0
15KP28A	28	31.1	5	25	47.5	316.0
15KP30	30	33.3	5	15	56.2	267.0
15KP30A	30	33.3	5	15	50.7	296.0
15KP33	33	36.7	5	10	60.6	248.0
15KP33A	33	36.7	5	10	54.8	274.0
15KP36	36	40.0	5	10	66.0	227.0
15KP36A	36	40.0	5	10	59.7	251.0
15KP40	40	44.4	5	10	72.8	206.0
15KP40A	40	44.4	5	10	65.8	228.0
15KP43	43	47.8	5	10	77.1	195.0
15KP43A	43	47.8	5	10	69.7	215.0
15KP45	45	50.0	5	10	80.7	186.0
15KP45A	45	50.0	5	10	73.0	205.0
15KP48	48	53.3	5	10	85.9	175.0
15KP48A	48	53.3	5	10	77.7	193.0

\* = Add "C" or "CA" suffix for bidirectional device types.

# = See General Information for Impulse Current Waveform.

**TVS Diodes - 15000 Watt Specifications - 15KP Series Electrical Characteristics - (Continued)**

Part Number*	Rated Standoff Voltage Vwm (Volts)	Breakdown Voltage		Maximum Stand By Current @Vwm+ Id ( $\mu$ A)	10/1000 $\mu$ s Maximum Clamping Voltage @Ippm# Vc Max (Volts)	10/1000 $\mu$ s Rated Peak Impulse Current Ippm# (Amperes)
		Vbr (Volts) Min	@It (mA)			
15KP51	51	56.7	5	10	91.5	164.0
15KP51A	51	56.7	5	10	82.8	181.0
15KP54	54	60.0	5	10	96.8	155.0
15KP54A	54	60.0	5	10	87.5	171.0
15KP58	58	64.4	5	10	104.0	144.0
15KP58A	58	64.4	5	10	94.0	160.0
15KP60	60	66.7	5	10	107.0	140.0
15KP60A	60	66.7	5	10	97.3	154.0
15KP64	64	71.1	5	10	115.0	130.0
15KP64A	64	71.1	5	10	104.0	144.0
15KP70	70	77.8	5	10	126.0	119.0
15KP70A	70	77.8	5	10	114.0	132.0
15KP75	75	83.3	5	10	135.0	111.0
15KP75A	75	83.3	5	10	122.0	123.0
15KP78	78	86.7	5	10	140.0	107.0
15KP78A	78	86.7	5	10	126.0	119.0
15KP85	85	94.4	5	10	152.0	99.0
15KP85A	85	94.4	5	10	137.0	109.0
15KP90	90	100.0	5	10	160.0	94.0
15KP90A	90	100.0	5	10	146.0	103.0
15KP100	100	111.0	5	10	179.0	84.0
15KP110	110	122.0	5	10	196.0	77.0
15KP120	120	133.0	5	10	214.0	70.0
15KP130	130	144.0	5	10	231.0	65.0

\* = Add "C" or "CA" suffix for bidirectional device types.

# = See General Information for Impulse Current Waveform.

**TVS Diodes - 15000 Watt Specifications - 15KP Series Electrical Characteristics - (Continued)**

Part Number*	Rated Standoff Voltage V <sub>wm</sub> (Volts)	Breakdown Voltage		Maximum Stand By Current @V <sub>wm</sub> + I <sub>d</sub> ( $\mu$ A)	10/1000 $\mu$ s Maximum Clamping Voltage @I <sub>ppm</sub> # V <sub>c</sub> Max (Volts)	10/1000 $\mu$ s Rated Peak Impulse Current I <sub>ppm</sub> # (Amperes)
		V <sub>br</sub> (Volts) Min	@I <sub>t</sub> (mA)			
15KP150	150	167.0	5	10	268.0	56.0
15KP160	160	178.0	5	10	287.0	52.0
15KP170	170	189.0	5	10	304.0	49.0
15KP180	180	200.0	5	10	321.0	47.0
15KP200	200	222.0	5	10	356.0	42.0
15KP220	220	245.0	5	10	393.0	38.0
15KP240	240	267.0	5	10	428.0	35.0
15KP260	260	289.0	5	10	464.0	32.0
15KP280	280	311.0	5	10	500.0	30.0

\* = Add "C" or "CA" suffix for bidirectional device types.

# = See General Information for Impulse Current Waveform.

## TVS Diodes - 15000 Watt - 15KP Series Features

### 15KP Series Features

- 15000 watt peak pulse power dissipation
- Available in voltages from 17V to 280V
- Unidirectional and Bidirectional
- Glass passivated junction
- Low clamping factor
- Each device 100% surge tested
- Available in bulk or tape and reel (Reel quantity = 1,000 pieces)

### Absolute Maximum Ratings

- Peak pulse power dissipation (Pppm) at 25°C..... 15000W
- Steady state power dissipation at lead temperature = 75°C (Lead length 3/8" min.)..... 5W
- Operating and storage temperatures..... -65°C to + 175°C

### Mechanical Dimensions

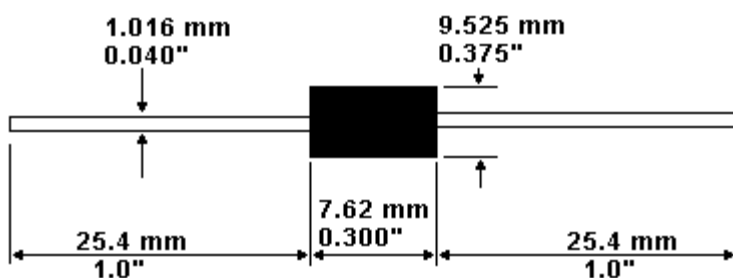

**TVS Diodes - Surface Mount - 600 Watt Specifications - P6SMBJ Series Electrical Characteristics**

Part Number*	Uni Part Marking	Bi Part Marking	Rated Standoff Voltage Vwm (Volts)	Breakdown Voltage		Maximum Stand By Current @Vwm+ Id ( $\mu$ A)	10/1000 $\mu$ s Maximum Clamping Voltage @Ippm# Vc Max (Volts)	10/1000 $\mu$ s Rated Peak Impulse Current Ippm# (Amperes)
				Vbr Min (Volts)	@It (mA)			
P6SMBJ5.0	KD	AD	5.0	6.40	10	800.0	9.6	62.5
P6SMBJ5.0A	KE	AE	5.0	6.40	10	800.0	9.2	65.2
P6SMBJ6.0	KF	AF	6.0	6.67	10	800.0	11.4	52.6
P6SMBJ6.0A	KG	AG	6.0	6.67	10	800.0	10.3	58.3
P6SMBJ6.5	KH	AH	6.5	7.22	10	500.0	12.3	48.7
P6SMBJ6.5A	KK	AK	6.5	7.22	10	500.0	11.2	53.6
P6SMBJ7.0	KL	AL	7.0	7.78	10	200.0	13.3	45.1
P6SMBJ7.0A	KM	AM	7.0	7.78	10	200.0	12.0	50.0
P6SMBJ7.5	KN	AN	7.5	8.33	1	100.0	14.3	42.0
P6SMBJ7.5A	KP	AP	7.5	8.33	1	100.0	12.9	46.5
P6SMBJ8.0	KQ	AQ	8.0	8.89	1	50.0	15.0	40.0
P6SMBJ8.0A	KR	AR	8.0	8.89	1	50.0	13.6	44.1
P6SMBJ8.5	KS	AS	8.5	9.44	1	20.0	15.9	37.7
P6SMBJ8.5A	KT	AT	8.5	9.44	1	20.0	14.4	41.7
P6SMBJ9.0	KU	AU	9.0	10.00	1	10.0	16.9	35.5
P6SMBJ9.0A	KV	AV	9.0	10.00	1	10.0	15.4	39.0
P6SMBJ10	KW	AW	10.0	11.10	1	5.0	18.8	31.9
P6SMBJ10A	KX	AX	10.0	11.10	1	5.0	17.0	35.3
P6SMBJ11	KY	AY	11.0	12.20	1	5.0	20.1	29.9
P6SMBJ11A	KZ	AZ	11.0	12.20	1	5.0	18.2	33.0
P6SMBJ12	LD	BD	12.0	13.30	1	5.0	22.0	27.3
P6SMBJ12A	LE	BE	12.0	13.30	1	5.0	19.9	30.2
P6SMBJ13	LF	BF	13.0	14.40	1	5.0	23.8	25.2
P6SMBJ13A	LG	BG	13.0	14.40	1	5.0	21.5	27.9
P6SMBJ14	LH	BH	14.0	15.60	1	5.0	25.8	23.3
P6SMBJ14A	LK	BK	14.0	15.60	1	5.0	23.2	25.8

\* = Add "C" or "CA" suffix for bidirectional device types.

+ = For Bidirectional Types Having Vwm  $\leq$  10V, their Id limit is doubled.

# = See General Information for Impulse Current Waveform.



**TVS Diodes - Surface Mount - 600 Watt Specifications - P6SMBJ Series Electrical Characteristics - (Continued)**

Part Number*	Uni Part Marking	Bi Part Marking	Rated Standoff Voltage Vwm (Volts)	Breakdown Voltage		Maximum Stand By Current @Vwm+ Id ( $\mu$ A)	10/1000 $\mu$ s Maximum Clamping Voltage @Ippm# Vc Max (Volts)	10/1000 $\mu$ s Rated Peak Impulse Current Ippm# (Amperes)
				Vbr Min (Volts)	@It (mA)			
P6SMBJ15	LL	BL	15.0	16.70	1	5.0	26.9	22.3
P6SMBJ15A	LM	BM	15.0	16.70	1	5.0	24.4	24.0
P6SMBJ16	LN	BN	16.0	17.80	1	5.0	28.8	20.8
P6SMBJ16A	LP	BP	16.0	17.80	1	5.0	26.0	23.1
P6SMBJ17	LQ	BQ	17.0	18.90	1	5.0	30.5	19.7
P6SMBJ17A	LR	BR	17.0	18.90	1	5.0	27.6	21.7
P6SMBJ18	LS	BS	18.0	20.00	1	5.0	32.2	18.6
P6SMBJ18A	LT	BT	18.0	20.00	1	5.0	29.2	20.5
P6SMBJ20	LU	BU	20.0	22.20	1	5.0	35.8	16.7
P6SMBJ20A	LV	BV	20.0	22.20	1	5.0	32.4	18.5
P6SMBJ22	LW	BW	22.0	24.40	1	5.0	39.4	15.2
P6SMBJ22A	LX	BX	22.0	24.40	1	5.0	35.5	16.9
P6SMBJ24	LY	BY	24.0	26.70	1	5.0	43.0	14.0
P6SMBJ24A	LZ	BZ	24.0	26.70	1	5.0	38.9	15.4
P6SMBJ26	MD	CD	26.0	28.90	1	5.0	46.6	12.4
P6SMBJ26A	ME	CE	26.0	28.90	1	5.0	42.1	14.2
P6SMBJ28	MF	CF	28.0	31.10	1	5.0	50.0	12.0
P6SMBJ28A	MG	CG	28.0	31.10	1	5.0	45.4	13.2
P6SMBJ30	MH	CH	30.0	33.30	1	5.0	53.5	11.2
P6SMBJ30A	MK	CK	30.0	33.30	1	5.0	46.6	12.4
P6SMBJ33	ML	CL	33.0	36.70	1	5.0	59.0	10.2
P6SMBJ33A	MM	CM	33.0	36.70	1	5.0	53.3	11.3
P6SMBJ36	MN	CN	36.0	40.00	1	5.0	64.3	9.3
P6SMBJ36A	MP	CP	36.0	40.00	1	5.0	58.1	10.3
P6SMBJ40	MQ	CQ	40.0	44.40	1	5.0	71.4	8.4
P6SMBJ40A	MR	CR	40.0	44.40	1	5.0	64.5	9.3

\* = Add "C" or "CA" suffix for bidirectional device types.

+ = For Bidirectional Types Having Vwm  $\leq$  10V, their Id limit is doubled.

# = See General Information for Impulse Current Waveform.

**TVS Diodes - Surface Mount - 600 Watt Specifications - P6SMBJ Series Electrical Characteristics - (Continued)**

Part Number*	Uni Part Marking	Bi Part Marking	Rated Standoff Voltage Vwm (Volts)	Breakdown Voltage		Maximum Stand By Current @Vwm+ Id ( $\mu$ A)	10/1000 $\mu$ s Maximum Clamping Voltage @Ippm# Vc Max (Volts)	10/1000 $\mu$ s Rated Peak Impulse Current Ippm# (Amperes)
				Vbr Min (Volts)	@It (mA)			
P6SMBJ43	MS	CS	43.0	47.80	1	5.0	76.7	7.8
P6SMBJ43A	MT	CT	43.0	47.80	1	5.0	69.4	8.6
P6SMBJ45	MU	CU	45.0	50.00	1	5.0	80.3	7.5
P6SMBJ45A	MV	CV	45.0	50.00	1	5.0	72.7	8.3
P6SMBJ48	MW	CW	48.0	53.30	1	5.0	85.5	7.0
P6SMBJ48A	MX	CX	48.0	53.30	1	5.0	77.4	7.7
P6SMBJ51	MY	CY	51.0	56.70	1	5.0	91.1	6.6
P6SMBJ51A	MZ	CZ	51.0	56.70	1	5.0	82.4	7.3
P6SMBJ54	ND	DD	54.0	60.00	1	5.0	96.3	6.2
P6SMBJ54A	NE	DE	54.0	60.00	1	5.0	87.1	6.9
P6SMBJ58	NF	DF	58.0	64.40	1	5.0	103.0	5.8
P6SMBJ58A	NG	DG	58.0	64.40	1	5.0	93.6	6.4
P6SMBJ60	NH	DH	60.0	66.70	1	5.0	107.0	5.6
P6SMBJ60A	NK	DK	60.0	66.70	1	5.0	96.8	6.2
P6SMBJ64	NL	DL	64.0	71.10	1	5.0	114.0	5.3
P6SMBJ64A	NM	DM	64.0	71.10	1	5.0	103.0	5.8
P6SMBJ70	NN	DN	70.0	77.80	1	5.0	125.0	4.8
P6SMBJ70A	NP	DP	70.0	77.80	1	5.0	113.0	5.3
P6SMBJ75	NQ	DQ	75.0	83.30	1	5.0	134.0	4.5
P6SMBJ75A	NR	DR	75.0	83.30	1	5.0	121.0	4.9
P6SMBJ78	NS	DS	78.0	86.70	1	5.0	139.0	4.3
P6SMBJ78A	NT	DT	78.0	86.70	1	5.0	126.0	4.7
P6SMBJ85	NU	DU	85.0	94.40	1	5.0	151.0	3.9
P6SMBJ85A	NV	DV	85.0	94.40	1	5.0	137.0	4.4
P6SMBJ90	NW	DW	90.0	100.00	1	5.0	160.0	3.8
P6SMBJ90A	NX	DX	90.0	100.00	1	5.0	146.0	4.1

\* = Add "C" or "CA" suffix for bidirectional device types.

+ = For Bidirectional Types Having Vwm  $\leq$  10V, their Id limit is doubled.

# = See General Information for Impulse Current Waveform.

**TVS Diodes - Surface Mount - 600 Watt Specifications - P6SMBJ Series Electrical Characteristics - (Continued)**

Part Number*	Uni Part Marking	Bi Part Marking	Rated Standoff Voltage Vwm (Volts)	Breakdown Voltage		Maximum Stand By Current @Vwm+ Id ( $\mu$ A)	10/1000 $\mu$ s Maximum Clamping Voltage @Ippm# Vc Max (Volts)	10/1000 $\mu$ s Rated Peak Impulse Current Ippm# (Amperes)
				Vbr Min (Volts)	@It (mA)			
P6SMBJ100	NY	DY	100.0	111.00	1	5.0	179.0	3.4
P6SMBJ100A	NZ	DZ	100.0	111.00	1	5.0	162.0	3.7
P6SMBJ110	PD	ED	110.0	122.00	1	5.0	196.0	3.0
P6SMBJ110A	PE	EE	110.0	122.00	1	5.0	177.0	3.4
P6SMBJ120	PF	EF	120.0	133.00	1	5.0	214.0	2.8
P6SMBJ120A	PG	EG	120.0	133.00	1	5.0	193.0	3.1
P6SMBJ130	PH	EH	130.0	144.00	1	5.0	231.0	2.6
P6SMBJ130A	PK	EK	130.0	144.00	1	5.0	209.0	2.9
P6SMBJ150	PL	EL	150.0	167.00	1	5.0	268.0	2.2
P6SMBJ150A	PM	EM	150.0	167.00	1	5.0	243.0	2.5
P6SMBJ160	PN	EN	160.0	178.00	1	5.0	287.0	2.1
P6SMBJ160A	PP	EP	160.0	178.00	1	5.0	259.0	2.3
P6SMBJ170	PQ	EQ	170.0	189.00	1	5.0	304.0	2.0
P6SMBJ170A	PR	ER	170.0	189.00	1	5.0	275.0	2.2

\* = Add "C" or "CA" suffix for bidirectional device types.

+ = For Bidirectional Types Having Vwm  $\leq$  10V, their Id limit is doubled.

# = See General Information for Impulse Current Waveform.

## TVS Diodes - Surface Mount - 600 Watt - P6SMBJ Series Features

### P6SMBJ Series Features

- 600 watt peak pulse power dissipation
- Available in voltages from 5.0V to 170V
- Unidirectional and bidirectional
- Glass passivated junction
- Low clamping factor
- Each device 100% surge tested

### Absolute Maximum Ratings

- Peak pulse power dissipation (Pppm) at 25°C..... 600W
- Steady state power dissipation at 25°C ..... 5W
- Operating and storage temperatures..... -55°C to + 150°C

### Mechanical Characteristics

- DO214AA package
- UL94V-0 Thermoset Epoxy
- Solder plated terminals
- Solderable per MIL-STD-750 Method 2026

### Mechanical Dimensions

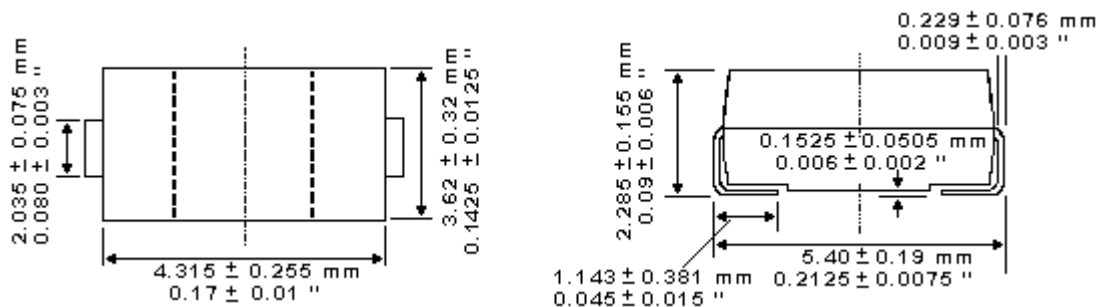

**TVS Diodes - Surface Mount - 1500 Watt Specifications - 1.5SMCJ Series Electrical Characteristics**

Part Number*	Uni Part Marking	Bi Part Marking	Rated Standoff Voltage Vwm (Volts)	Breakdown Voltage		Maximum Stand By Current @Vwm+ Id ( $\mu$ A)	10/1000 $\mu$ s Maximum Clamping Voltage @Ippm# Vc Max (Volts)	10/1000 $\mu$ s Rated Peak Impulse Current Ippm# (Amperes)
				Vbr Min (Volts)	@It (mA)			
1.5SMCJ5.0	GDD	BDD	5.0	6.40	10	1000	9.6	156.2
1.5SMCJ5.0A	GDE	BDE	5.0	6.40	10	1000	9.2	163.0
1.5SMCJ6.0	GDF	BDF	6.0	6.67	10	1000	11.4	131.6
1.5SMCJ6.0A	GDG	BDG	6.0	6.67	10	1000	10.3	145.6
1.5SMCJ6.5	GDH	BDH	6.5	7.22	10	500	12.3	122.0
1.5SMCJ6.5A	GDK	BDK	6.5	7.22	10	500	11.2	133.9
1.5SMCJ7.0	GDL	BDL	7.0	7.78	10	200	13.3	112.8
1.5SMCJ7.0A	GDM	BDM	7.0	7.78	10	200	12.0	125.0
1.5SMCJ7.5	GDN	BDN	7.5	8.33	1	100	14.3	104.9
1.5SMCJ7.5A	GDP	BDP	7.5	8.33	1	100	12.9	116.3
1.5SMCJ8.0	GDQ	BDQ	8.0	8.89	1	50	15.0	100.0
1.5SMCJ8.0A	GDR	BDR	8.0	8.89	1	50	13.6	110.3
1.5SMCJ8.5	GDS	BDS	8.5	9.44	1	25	15.9	94.3
1.5SMCJ8.5A	GDT	BDT	8.5	9.44	1	20	14.4	104.2
1.5SMCJ9.0	GDU	BDU	9.0	10.00	1	10	16.9	88.7
1.5SMCJ9.0A	GDV	BDV	9.0	10.00	1	10	15.4	97.4
1.5SMCJ10	GDW	BDW	10.0	11.10	1	5	18.8	79.8
1.5SMCJ10A	GDX	BDX	10.0	11.10	1	5	17.0	88.2
1.5SMCJ11	GDY	BDY	11.0	12.20	1	5	20.1	74.6
1.5SMCJ11A	GDZ	BDZ	11.0	12.20	1	5	18.2	82.4
1.5SMCJ12	GED	BED	12.0	13.30	1	5	22.0	68.2
1.5SMCJ12A	GEE	BEE	12.0	13.30	1	5	19.9	75.3
1.5SMCJ13	GEF	BEF	13.0	14.40	1	5	23.8	63.0
1.5SMCJ13A	GEG	BEG	13.0	14.40	1	5	21.5	69.7
1.5SMCJ14	GEH	BEH	14.0	15.60	1	5	25.8	58.1
1.5SMCJ14A	GEK	BEK	14.0	15.60	1	5	23.2	64.7

\* = Add "C" or "CA" suffix for bidirectional device types.

+ = For Bidirectional Types Having Vwm  $\leq$  10V, their Id limit is doubled.

# = See General Information for Impulse Current Waveform.

**TVS Diodes - Surface Mount - 1500 Watt Specifications - 1.5SMCJ Series Electrical Characteristics - (Continued)**

Part Number*	Uni Part Marking	Bi Part Marking	Rated Standoff Voltage Vwm (Volts)	Breakdown Voltage		Maximum Stand By Current @Vwm+ Id ( $\mu$ A)	10/1000 $\mu$ s Maximum Clamping Voltage @Ippm# Vc Max (Volts)	10/1000 $\mu$ s Rated Peak Impulse Current Ippm# (Amperes)
				Vbr Min (Volts)	@It (mA)			
				1.5SMCJ15	GEL			
1.5SMCJ15A	GEM	BEM	15.0	16.70	1	5	24.4	61.5
1.5SMCJ16	GEN	BEN	16.0	17.80	1	5	28.8	52.1
1.5SMCJ16A	GEP	BEP	16.0	17.80	1	5	26.0	57.7
1.5SMCJ17	GEQ	BEQ	17.0	18.90	1	5	30.5	49.2
1.5SMCJ17A	GER	BER	17.0	18.90	1	5	27.6	53.3
1.5SMCJ18	GES	BES	18.0	20.00	1	5	32.2	46.6
1.5SMCJ18A	GET	BET	18.0	20.00	1	5	29.2	51.4
1.5SMCJ20	GEU	BEU	20.0	22.20	1	5	35.8	41.9
1.5SMCJ20A	GEV	BEV	20.0	22.20	1	5	32.4	46.3
1.5SMCJ22	GEW	BEW	22.0	24.40	1	5	39.4	38.1
1.5SMCJ22A	GEX	BEX	22.0	24.40	1	5	35.5	42.2
1.5SMCJ24	GEY	BEY	24.0	26.70	1	5	43.0	34.9
1.5SMCJ24A	GEZ	BEZ	24.0	26.70	1	5	38.9	38.6
1.5SMCJ26	GFD	BFD	26.0	28.90	1	5	46.6	32.2
1.5SMCJ26A	GFE	BFE	26.0	28.90	1	5	42.1	35.6
1.5SMCJ28	GFF	BFF	28.0	31.10	1	5	50.0	30.0
1.5SMCJ28A	GFG	BFG	28.0	31.10	1	5	45.4	33.0
1.5SMCJ30	GFH	BFH	30.0	33.30	1	5	53.5	28.0
1.5SMCJ30A	GFK	BFK	30.0	33.30	1	5	48.4	31.0
1.5SMCJ33	GFL	BFL	33.0	36.70	1	5	59.0	25.2
1.5SMCJ33A	GFM	BFM	33.0	36.70	1	5	53.3	28.1
1.5SMCJ36	GFN	BFN	36.0	40.00	1	5	64.3	23.3
1.5SMCJ36A	GFP	BFP	36.0	40.00	1	5	58.1	25.8
1.5SMCJ40	GFQ	BFQ	40.0	44.40	1	5	71.4	21.0
1.5SMCJ40A	GFR	BFR	40.0	44.40	1	5	64.5	23.2

\* = Add "C" or "CA" suffix for bidirectional device types.

+ = For Bidirectional Types Having Vwm  $\leq$  10V, their Id limit is doubled.

# = See General Information for Impulse Current Waveform.

**TVS Diodes - Surface Mount - 1500 Watt Specifications - 1.5SMCJ Series Electrical Characteristics - (Continued)**

Part Number*	Uni Part Marking	Bi Part Marking	Rated Standoff Voltage Vwm (Volts)	Breakdown Voltage		Maximum Stand By Current @Vwm+ Id ( $\mu$ A)	10/1000 $\mu$ s Maximum Clamping Voltage @Ippm# Vc Max (Volts)	10/1000 $\mu$ s Rated Peak Impulse Current Ippm# (Amperes)
				Vbr Min (Volts)	@It (mA)			
				1.5SMCJ43	GFS			
1.5SMCJ43A	GFT	BFT	43.0	47.80	1	5	69.4	21.6
1.5SMCJ45	GFU	BFU	45.0	50.00	1	5	80.3	18.7
1.5SMCJ45A	GFV	BFV	45.0	50.00	1	5	72.7	20.6
1.5SMCJ48	GFW	BFW	48.0	53.30	1	5	85.5	17.5
1.5SMCJ48A	GFX	BFX	48.0	53.30	1	5	77.4	19.4
1.5SMCJ51	GFY	BFY	51.0	56.70	1	5	91.1	18.5
1.5SMCJ51A	GFZ	BFZ	51.0	56.70	1	5	82.4	18.2
1.5SMCJ54	GGD	BGD	54.0	60.00	1	5	96.3	15.6
1.5SMCJ54A	GGE	BGE	54.0	60.00	1	5	87.1	17.2
1.5SMCJ58	GGF	BGF	58.0	64.40	1	5	103.0	14.6
1.5SMCJ58A	GGG	BGG	58.0	64.40	1	5	93.6	16.0
1.5SMCJ60	GGH	BGH	60.0	66.70	1	5	107.0	14.0
1.5SMCJ60A	GGK	BGK	60.0	66.70	1	5	96.8	15.5
1.5SMCJ64	GGL	BGL	64.0	71.10	1	5	114.0	13.2
1.5SMCJ64A	GGM	BGM	64.0	71.10	1	5	103.0	14.6
1.5SMCJ70	GGN	BGN	70.0	77.80	1	5	125.0	12.0
1.5SMCJ70A	GGP	BGP	70.0	77.80	1	5	113.0	13.3
1.5SMCJ75	GGQ	BGQ	75.0	83.30	1	5	134.0	11.2
1.5SMCJ75A	GGR	BGR	75.0	83.30	1	5	121.0	12.4
1.5SMCJ78	GGS	BGS	78.0	86.70	1	5	139.0	10.8
1.5SMCJ78A	GGT	BGT	78.0	86.70	1	5	126.0	11.4
1.5SMCJ85	GGU	BGU	85.0	94.40	1	5	151.0	9.9
1.5SMCJ85A	GGV	BGV	85.0	94.40	1	5	137.0	10.4
1.5SMCJ90	GGW	BGW	90.0	100.00	1	5	160.0	9.4
1.5SMCJ90A	GGX	BGX	90.0	100.00	1	5	146.0	10.3

\* = Add "C" or "CA" suffix for bidirectional device types.

+ = For Bidirectional Types Having Vwm  $\leq$  10V, their Id limit is doubled.

# = See General Information for Impulse Current Waveform.

**TVS Diodes - Surface Mount - 1500 Watt Specifications - 1.5SMCJ Series Electrical Characteristics - (Continued)**

Part Number*	Uni Part Marking	Bi Part Marking	Rated Standoff Voltage Vwm (Volts)	Breakdown Voltage		Maximum Stand By Current @Vwm+ Id (µA)	10/1000µs Maximum Clamping Voltage @Ippm# Vc Max (Volts)	10/1000µs Rated Peak Impulse Current Ippm# (Amperes)
				Vbr Min (Volts)	@It (mA)			
1.5SMCJ100	GGY	BGY	100.0	111.00	1	5	179.0	8.4
1.5SMCJ100A	GGZ	BGZ	100.0	111.0	1	5	162.0	9.3
1.5SMCJ110	GHD	BHD	110.0	122.0	1	5	196.0	7.7
1.5SMCJ110A	GHE	BHE	110.0	122.0	1	5	177.0	8.4
1.5SMCJ120	GHF	BHF	120.0	133.0	1	5	214.0	7.0
1.5SMCJ120A	GHG	BHG	120.0	133.0	1	5	193.0	7.9
1.5SMCJ130	GHH	BHH	130.0	144.00	1	5	231.0	6.5
1.5SMCJ130A	GHK	BHK	130.0	144.00	1	5	209.0	7.2
1.5SMCJ150	GHL	BHL	150.0	167.00	1	5	268.0	5.6
1.5SMCJ150A	GHM	BHM	150.0	167.00	1	5	243.0	6.2
1.5SMCJ160	GHN	BHN	160.0	178.00	1	5	287.0	5.2
1.5SMCJ160A	GHP	BHP	160.0	178.00	1	5	259.0	5.8
1.5SMCJ170	GHQ	BHQ	170.0	189.00	1	5	304.0	4.9
1.5SMCJ170A	GHR	BHR	170.0	189.00	1	5	275.0	5.5

\* = Add "C" or "CA" suffix for bidirectional device types.

+ = For Bidirectional Types Having Vwm <= 10V, their Id limit is doubled.

# = See General Information for Impulse Current Waveform.



## TVS Diodes - Surface Mount - 1500 Watt - 1.5SMCJ Series Features

### 1.5SMCJ Series Features

- 1500 watt peak pulse power dissipation
- Available in voltages from 5.0V to 170V
- Unidirectional and bidirectional
- Glass passivated junction
- Low clamping factor
- Each device 100% surge tested

### Absolute Maximum Ratings

- Peak pulse power dissipation (Pppm) at 25°C..... 1500W
- Operating and storage temperatures..... -55°C to + 150°C

### Mechanical Characteristics

- DO214AB package
- UL94V-0 Thermoset Epoxy
- Solder plated terminals
- Solderable per MIL-STD-750 Method 2026

### Mechanical Dimensions

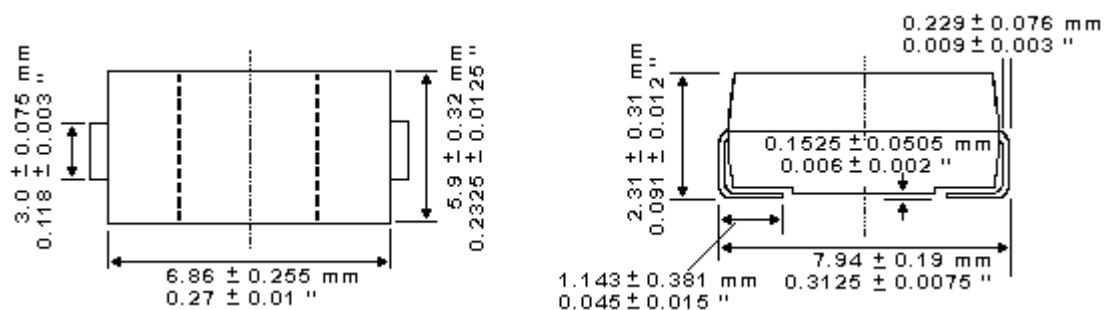

**TVS Diodes - Surface Mount - 400 Watt Specifications - P4SMAJ Series Electrical Characteristics**

Part Number*	Uni Part Marking	Bi Part Marking	Rated Standoff Voltage Vwm (Volts)	Breakdown Voltage		Maximum Stand By Current @Vwm+ Id ( $\mu$ A)	10/1000 $\mu$ s Maximum Clamping Voltage @Ippm# Vc Max (Volts)	10/1000 $\mu$ s Rated Peak Impulse Current Ippm# (Amperes)
				Vbr Min (Volts)	@It (mA)			
P4SMAJ5.0	HD	TD	5.0	6.40	10	800.0	9.6	41.6
P4SMAJ5.0A	HE	TE	5.0	6.40	10	800.0	9.2	43.5
P4SMAJ6.0	HF	TF	6.0	6.67	10	800.0	11.4	35.1
P4SMAJ6.0A	HG	TG	6.0	6.67	10	800.0	10.3	38.8
P4SMAJ6.5	HH	TH	6.5	7.22	10	500.0	12.3	32.5
P4SMAJ6.5A	HK	TK	6.5	7.22	10	500.0	11.2	35.7
P4SMAJ7.0	HL	TL	7.0	7.78	10	200.0	13.3	30.1
P4SMAJ7.0A	HM	TM	7.0	7.78	10	200.0	12.0	33.3
P4SMAJ7.5	HN	TN	7.5	8.33	1	100.0	14.3	28.0
P4SMAJ7.5A	HP	TP	7.5	8.33	1	100.0	12.9	31.0
P4SMAJ8.0	HQ	TQ	8.0	8.89	1	50.0	15.0	26.5
P4SMAJ8.0A	HR	TR	8.0	8.89	1	50.0	13.6	29.4
P4SMAJ8.5	HS	TS	8.5	9.44	1	10.0	15.9	25.1
P4SMAJ8.5A	HT	TT	8.5	9.44	1	10.0	14.4	27.7
P4SMAJ9.0	HU	TU	9.0	10.00	1	5.0	16.9	23.6
P4SMAJ9.0A	HV	TV	9.0	10.00	1	5.0	15.4	26.0
P4SMAJ10	HW	TW	10.0	11.10	1	5.0	18.8	21.2
P4SMAJ10A	HGX	TX	10.0	11.10	1	5.0	17.0	23.5
P4SMAJ11	HY	TY	11.0	12.20	1	5.0	20.1	20.0
P4SMAJ11A	HZ	TZ	11.0	12.20	1	5.0	18.2	22.0
P4SMAJ12	ID	UD	12.0	13.30	1	5.0	22.0	18.1
P4SMAJ12A	IE	UE	12.0	13.30	1	5.0	19.9	20.1
P4SMAJ13	IF	UF	13.0	14.40	1	5.0	23.8	16.8
P4SMAJ13A	IG	UG	13.0	14.40	1	5.0	21.5	18.6
P4SMAJ14	IH	UH	14.0	15.60	1	5.0	25.8	15.5
P4SMAJ14A	IK	UK	14.0	15.60	1	5.0	23.2	17.2

\* = Add "C" or "CA" suffix for bidirectional device types.

+ = For Bidirectional Types Having Vwm  $\leq$  10V, their Id limit is doubled.

# = See General Information for Impulse Current Waveform.

**TVS Diodes - Surface Mount - 400 Watt Specifications - P4SMAJ Series Electrical Characteristics - (Continued)**

Part Number*	Uni Part Marking	Bi Part Marking	Rated Standoff Voltage Vwm (Volts)	Breakdown Voltage		Maximum Stand By Current @Vwm+ Id ( $\mu$ A)	10/1000 $\mu$ s Maximum Clamping Voltage @Ippm# Vc Max (Volts)	10/1000 $\mu$ s Rated Peak Impulse Current Ippm# (Amperes)
				Vbr Min (Volts)	@It (mA)			
P4SMAJ15	IL	UL	15.0	16.70	1	5.0	26.9	14.8
P4SMAJ15A	IM	UM	15.0	16.70	1	5.0	24.4	16.4
P4SMAJ16	IN	UN	16.0	17.80	1	5.0	28.8	13.8
P4SMAJ16A	IP	UP	16.0	17.80	1	5.0	26.0	15.3
P4SMAJ17	IQ	UQ	17.0	18.90	1	5.0	30.5	13.1
P4SMAJ17A	IR	UR	17.0	18.90	1	5.0	27.6	14.5
P4SMAJ18	IS	US	18.0	20.00	1	5.0	32.2	12.4
P4SMAJ18A	IT	UT	18.0	20.00	1	5.0	29.2	13.7
P4SMAJ20	IU	UU	20.0	22.20	1	5.0	35.8	11.1
P4SMAJ20A	IV	UV	20.0	22.20	1	5.0	32.4	12.3
P4SMAJ22	IW	UW	22.0	24.40	1	5.0	39.4	10.1
P4SMAJ22A	IX	UX	22.0	24.40	1	5.0	35.5	11.2
P4SMAJ24	IY	UY	24.0	26.70	1	5.0	43.0	9.3
P4SMAJ24A	IZ	UZ	24.0	26.70	1	5.0	38.9	10.3
P4SMAJ26	JD	VD	26.0	28.90	1	5.0	46.6	8.6
P4SMAJ26A	JE	VE	26.0	28.90	1	5.0	42.1	9.5
P4SMAJ28	JF	VF	28.0	31.10	1	5.0	50.0	8.0
P4SMAJ28A	JG	VG	28.0	31.10	1	5.0	45.4	8.8
P4SMAJ30	JH	VH	30.0	33.30	1	5.0	53.5	7.5
P4SMAJ30A	JK	VK	30.0	33.30	1	5.0	48.4	8.3
P4SMAJ33	JL	VL	33.0	36.70	1	5.0	59.0	6.8
P4SMAJ33A	JM	VM	33.0	36.70	1	5.0	53.3	7.5
P4SMAJ36	JN	VN	36.0	40.00	1	5.0	64.3	6.2
P4SMAJ36A	JP	VP	36.0	40.00	1	5.0	58.1	6.9
P4SMAJ40	JQ	VQ	40.0	44.40	1	5.0	71.4	5.6
P4SMAJ40A	JR	VR	40.0	44.40	1	5.0	64.5	6.2

\* = Add "C" or "CA" suffix for bidirectional device types.

+ = For Bidirectional Types Having Vwm  $\leq$  10V, their Id limit is doubled.

# = See General Information for Impulse Current Waveform.

**TVS Diodes - Surface Mount - 400 Watt Specifications - P4SMAJ Series Electrical Characteristics - (Continued)**

Part Number*	Uni Part Marking	Bi Part Marking	Rated Standoff Voltage Vwm (Volts)	Breakdown Voltage		Maximum Stand By Current @Vwm+ Id ( $\mu$ A)	10/1000 $\mu$ s Maximum Clamping Voltage @Ippm# Vc Max (Volts)	10/1000 $\mu$ s Rated Peak Impulse Current Ippm# (Amperes)
				Vbr Min (Volts)	@It (mA)			
P4SMAJ43	JS	VS	43.0	47.80	1	5.0	76.7	5.2
P4SMAJ43A	JT	VT	43.0	47.80	1	5.0	69.4	5.7
P4SMAJ45	JU	VU	45.0	50.00	1	5.0	80.3	5.0
P4SMAJ45A	JV	VV	45.0	50.00	1	5.0	72.7	5.5
P4SMAJ48	JW	VW	48.0	53.30	1	5.0	85.5	4.7
P4SMAJ48A	JX	VX	48.0	53.30	1	5.0	77.4	5.2
P4SMAJ51	JY	VY	51.0	56.70	1	5.0	91.1	4.4
P4SMAJ51A	JZ	VZ	51.0	56.70	1	5.0	82.4	4.9
P4SMAJ54	RD	WD	54.0	60.00	1	5.0	96.3	4.2
P4SMAJ54A	RE	WE	54.0	60.00	1	5.0	87.1	4.6
P4SMAJ58	RF	WF	58.0	64.40	1	5.0	103.0	3.9
P4SMAJ58A	RG	WG	58.0	64.40	1	5.0	93.6	4.3
P4SMAJ60	RH	WH	60.0	66.70	1	5.0	107.0	3.7
P4SMAJ60A	RK	WK	60.0	66.70	1	5.0	96.8	4.1
P4SMAJ64	RL	WL	64.0	71.10	1	5.0	114.0	3.5
P4SMAJ64A	RM	WM	64.0	71.10	1	5.0	103.0	3.9
P4SMAJ70	RN	WN	70.0	77.80	1	5.0	125.0	3.2
P4SMAJ70A	RP	WP	70.0	77.80	1	5.0	113.0	3.5
P4SMAJ75	RQ	WQ	75.0	83.30	1	5.0	134.0	3.0
P4SMAJ75A	RR	WR	75.0	83.30	1	5.0	121.0	3.3
P4SMAJ78	RS	WS	78.0	86.70	1	5.0	139.0	2.9
P4SMAJ78A	RT	WT	78.0	86.70	1	5.0	126.0	2.2
P4SMAJ85	RU	WU	85.0	94.40	1	5.0	151.0	2.6
P4SMAJ85A	RV	WV	85.0	94.40	1	5.0	137.0	2.9
P4SMAJ90	RW	WW	90.0	100.00	1	5.0	160.0	2.5
P4SMAJ90A	RX	WX	90.0	100.00	1	5.0	146.0	2.7

\* = Add "C" or "CA" suffix for bidirectional device types.

+ = For Bidirectional Types Having Vwm  $\leq$  10V, their Id limit is doubled.

# = See General Information for Impulse Current Waveform.

**TVS Diodes - Surface Mount - 400 Watt Specifications - P4SMAJ Series Electrical Characteristics - (Continued)**

Part Number*	Uni Part Marking	Bi Part Marking	Rated Standoff Voltage Vwm (Volts)	Breakdown Voltage		Maximum Stand By Current @Vwm+ Id ( $\mu$ A)	10/1000 $\mu$ s Maximum Clamping Voltage @Ippm# Vc Max (Volts)	10/1000 $\mu$ s Rated Peak Impulse Current Ippm# (Amperes)
				Vbr Min (Volts)	@It (mA)			
P4SMAJ100	RY	WY	100.0	111.00	1	5.0	179.0	2.2
P4SMAJ100A	RZ	WZ	100.0	111.00	1	5.0	162.0	2.5
P4SMAJ110	SD	XD	110.0	122.00	1	5.0	196.0	2.0
P4SMAJ110A	SE	XE	110.0	122.00	1	5.0	177.0	2.3
P4SMAJ120	SF	XF	120.0	133.00	1	5.0	214.0	1.9
P4SMAJ120A	SG	XG	120.0	133.00	1	5.0	193.0	2.0
P4SMAJ130	SH	XH	130.0	144.00	1	5.0	231.0	1.7
P4SMAJ130A	SK	XK	130.0	144.00	1	5.0	209.0	1.9
P4SMAJ150	SL	XL	150.0	167.00	1	5.0	268.0	1.5
P4SMAJ150A	SM	XM	150.0	167.00	1	5.0	243.0	1.6
P4SMAJ160	SN	XN	160.0	178.00	1	5.0	287.0	1.4
P4SMAJ160A	SP	XP	160.0	178.00	1	5.0	259.0	1.5
P4SMAJ170	SQ	XQ	170.0	189.00	1	5.0	304.0	1.3
P4SMAJ170A	SR	XR	170.0	189.00	1	5.0	275.0	1.4

\* = Add "C" or "CA" suffix for bidirectional device types.

+ = For Bidirectional Types Having Vwm  $\leq$  10V, their Id limit is doubled.

# = See General Information for Impulse Current Waveform.

## TVS Diodes - Surface Mount - 400 Watt - P4SMAJ Series Features

### P4SMAJ Series Features

- 400 watt peak pulse power dissipation
- Available in voltages from 5.0V to 170V
- Unidirectional and bidirectional
- Glass passivated junction
- Low clamping factor
- Each device 100% surge tested

### Absolute Maximum Ratings

- Peak pulse power dissipation (Pppm) at 25°C..... 400W
- Operating and storage temperatures..... -55°C to + 150°C

### Mechanical Characteristics

- DO214AC package
- UL94V-0 Thermoset Epoxy
- Solder plated terminals
- Solderable per MIL-STD-750 Method 2026

### Mechanical Dimensions

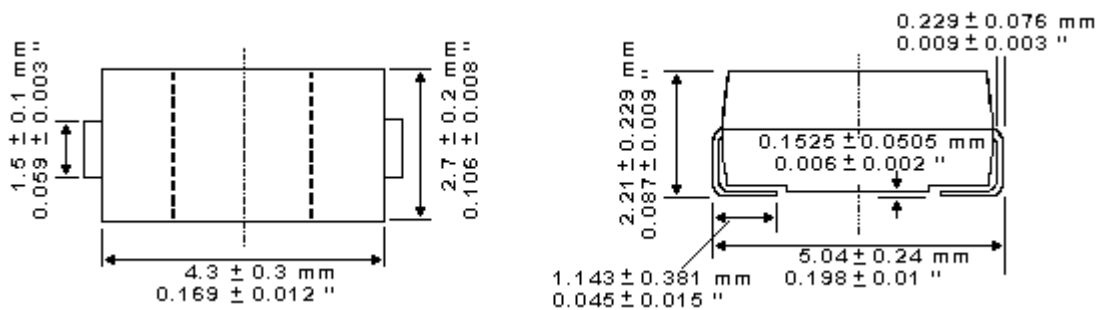

**TVS Diodes - Surface Mount - 3000 Watt Specifications - 3.0SMCJ Series Electrical Characteristics**

Part Number*	Uni Part Marking	Bi Part Marking	Breakdown Voltage		@It	Maximum Stand By Current @Vwm+ Id	10/1000µs Maximum Clamping Voltage @Ippm# Vc Max	10/1000µs Rated Peak Impulse Current Ippm#
			Rated Standoff Voltage Vwm	Vbr Min				
			(Volts)	(Volts)				
3.0SMCJ5.0	HDD	IDD	5.0	6.40	10	1000.0	9.6	312.5
3.0SMCJ5.0A	HDE	IDE	5.0	6.40	10	1000.0	9.2	326.0
3.0SMCJ6.0	HDF	IDF	6.0	6.67	10	1000.0	11.4	263.2
3.0SMCJ6.0A	HDG	IDG	6.0	6.67	10	1000.0	10.3	291.3
3.0SMCJ6.5	HDH	IDH	6.5	7.22	10	500.0	12.3	243.9
3.0SMCJ6.5A	HDK	IDK	6.5	7.22	10	500.0	11.2	267.9
3.0SMCJ7.0	HDL	IDL	7.0	7.78	10	200.0	13.3	225.6
3.0SMCJ7.0A	HDM	IDM	7.0	7.78	10	200.0	12.0	250.0
3.0SMCJ7.5	HDN	IDN	7.5	8.33	1	100.0	14.3	209.8
3.0SMCJ7.5A	HDP	IDP	7.5	8.33	1	100.0	12.9	232.6
3.0SMCJ8.0	HDQ	IDQ	8.0	8.89	1	50.0	15.0	200.0
3.0SMCJ8.0A	HDR	IDR	8.0	8.89	1	50.0	13.6	220.6
3.0SMCJ8.5	HDS	IDS	8.5	9.44	1	25.0	15.9	188.8
3.0SMCJ8.5A	HDT	IDT	8.5	9.44	1	25.0	14.4	208.4
3.0SMCJ9.0	HDU	IDU	9.0	10.00	1	10.0	16.9	177.4
3.0SMCJ9.0A	HDV	IDV	9.0	10.00	1	10.0	15.4	194.8
3.0SMCJ10	HDW	IDW	10.0	11.10	1	5.0	18.8	159.6
3.0SMCJ10A	HDX	IDX	10.0	11.10	1	5.0	17.0	176.4
3.0SMCJ11	HDY	IDY	11.0	12.20	1	5.0	20.1	149.2
3.0SMCJ11A	HDZ	IDZ	11.0	12.20	1	5.0	18.2	184.8
3.0SMCJ12	HED	IED	12.0	13.30	1	5.0	22.0	136.4
3.0SMCJ12A	HEE	IEE	12.0	13.30	1	5.0	19.9	150.6
3.0SMCJ13	HEF	IEF	13.0	14.40	1	5.0	23.8	126.0
3.0SMCJ13A	HEG	IEG	13.0	14.40	1	5.0	21.5	139.4
3.0SMCJ14	HEH	IEH	14.0	15.60	1	5.0	25.8	116.2
3.0SMCJ14A	HEK	IEK	14.0	15.60	1	5.0	23.2	129.4

\* = Add "C" or "CA" suffix for bidirectional device types.

+ = For Bidirectional Types Having Vwm &lt;= 10V, their Id limit is doubled.

# = See General Information for Impulse Current Waveform.

**TVS Diodes - Surface Mount - 3000 Watt Specifications - 3.0SMCJ Series Electrical Characteristics - (Continued)**

Part Number*	Uni Part Marking	Bi Part Marking	Breakdown Voltage		@It	Maximum Stand By Current @Vwm+ Id	10/1000µs Maximum Clamping Voltage @Ippm# Vc Max	10/1000µs Rated Peak Impulse Current Ippm#
			Rated Standoff Voltage Vwm	Vbr Min				
			(Volts)	(Volts)				
3.0SMCJ15	HEL	IEL	15.0	16.70	1	5.0	26.9	111.6
3.0SMCJ15A	HEM	IEM	15.0	16.70	1	5.0	24.4	123.0
3.0SMCJ16	HEN	IEN	16.0	17.80	1	5.0	28.8	104.2
3.0SMCJ16A	HEP	IEP	16.0	17.80	1	5.0	26.0	115.4
3.0SMCJ17	HEQ	IEQ	17.0	18.90	1	5.0	30.5	98.4
3.0SMCJ17A	HER	IER	17.0	18.90	1	5.0	27.6	106.6
3.0SMCJ18	HES	IES	18.0	20.00	1	5.0	32.2	93.2
3.0SMCJ18A	HET	IET	18.0	20.00	1	5.0	29.2	102.8
3.0SMCJ20	HEU	IEU	20.0	22.20	1	5.0	35.8	83.8
3.0SMCJ20A	HEV	IEV	20.0	22.20	1	5.0	32.4	92.6
3.0SMCJ22	HEW	IEW	22.0	24.40	1	5.0	39.4	76.2
3.0SMCJ22A	HEX	IEX	22.0	24.40	1	5.0	35.5	84.4
3.0SMCJ24	HEY	IEY	24.0	26.70	1	5.0	43.0	69.8
3.0SMCJ24A	HEZ	IEZ	24.0	26.70	1	5.0	38.9	77.2
3.0SMCJ26	HFD	IFD	26.0	28.90	1	5.0	46.6	64.4
3.0SMCJ26A	HFE	IFE	26.0	28.90	1	5.0	42.1	71.2
3.0SMCJ28	HFF	IFF	28.0	31.10	1	5.0	50.0	60.0
3.0SMCJ28A	HFG	IFG	28.0	31.10	1	5.0	45.4	66.0
3.0SMCJ30	HFH	IFH	30.0	33.30	1	5.0	53.5	56.0
3.0SMCJ30A	HFJ	IFJ	30.0	33.30	1	5.0	46.6	62.0
3.0SMCJ33	HFL	IFL	33.0	36.70	1	5.0	59.0	50.4
3.0SMCJ33A	HFM	IFM	33.0	36.70	1	5.0	53.3	56.2
3.0SMCJ36	HFN	IFN	36.0	40.00	1	5.0	64.3	46.6
3.0SMCJ36A	HFP	IFP	36.0	40.00	1	5.0	58.1	51.6
3.0SMCJ40	HFQ	IFQ	40.0	44.40	1	5.0	71.4	42.0
3.0SMCJ40A	HFR	IFR	40.0	44.40	1	5.0	64.5	46.4

\* = Add "C" or "CA" suffix for bidirectional device types.

+ = For Bidirectional Types Having Vwm &lt;= 10V, their Id limit is doubled.

# = See General Information for Impulse Current Waveform.



**TVS Diodes - Surface Mount - 3000 Watt Specifications - 3.0SMCJ Series Electrical Characteristics - (Continued)**

Part Number*	Uni Part Marking	Bi Part Marking	Breakdown Voltage		@It	Maximum Stand By Current @Vwm+ Id	10/1000 $\mu$ s	10/1000 $\mu$ s
			Rated Standoff Voltage Vwm	Vbr Min			Maximum Clamping Voltage @Ippm# Vc Max	Rated Peak Impulse Current Ippm#
			(Volts)	(Volts)			(mA)	( $\mu$ A)
3.0SMCJ43	HFS	IFS	43.0	47.80	1	5.0	76.7	39.2
3.0SMCJ43A	HFT	IFT	43.0	47.80	1	5.0	69.4	43.2
3.0SMCJ45	HFU	IFU	45.0	50.00	1	5.0	80.3	37.4
3.0SMCJ45A	HFV	IFV	45.0	50.00	1	5.0	72.7	41.2
3.0SMCJ48	HFW	IFW	48.0	53.30	1	5.0	85.5	35.0
3.0SMCJ48A	HFX	IFX	48.0	53.30	1	5.0	77.4	38.8
3.0SMCJ51	HFY	IFY	51.0	56.70	1	5.0	91.1	37.0
3.0SMCJ51A	HFZ	IFZ	51.0	56.70	1	5.0	82.4	36.4
3.0SMCJ54	HGD	IGD	54.0	60.00	1	5.0	96.3	31.2
3.0SMCJ54A	HGE	IGE	54.0	60.00	1	5.0	87.1	34.4
3.0SMCJ58	HGF	IGF	58.0	64.40	1	5.0	103.0	39.2
3.0SMCJ58A	HGG	IGG	58.0	64.40	1	5.0	93.6	32.0
3.0SMCJ60	HGH	IGH	60.0	66.70	1	5.0	107.0	28.0
3.0SMCJ60A	HGK	IGK	60.0	66.70	1	5.0	96.8	31.0
3.0SMCJ64	HGL	IGL	64.0	71.10	1	5.0	114.0	26.4
3.0SMCJ64A	HGM	IGM	64.0	71.10	1	5.0	103.0	29.2
3.0SMCJ70	HGN	IGN	70.0	77.80	1	5.0	125.0	24.0
3.0SMCJ70A	HGP	IGP	70.0	77.80	1	5.0	113.0	26.6
3.0SMCJ75	HGQ	IGQ	75.0	83.30	1	5.0	134.0	22.4
3.0SMCJ75A	HGR	IGR	75.0	83.30	1	5.0	121.0	24.8
3.0SMCJ78	HGS	IGS	78.0	86.70	1	5.0	139.0	21.6
3.0SMCJ78A	HGT	IGT	78.0	86.70	1	5.0	126.0	22.8
3.0SMCJ85	HGU	IGU	85.0	94.40	1	5.0	151.0	19.8
3.0SMCJ85A	HGV	IGV	85.0	94.40	1	5.0	137.0	20.8
3.0SMCJ90	HGW	IGW	90.0	100.00	1	5.0	160.0	18.8
3.0SMCJ90A	HGX	IGX	90.0	100.00	1	5.0	146.0	20.6

\* = Add "C" or "CA" suffix for bidirectional device types.

+ = For Bidirectional Types Having Vwm  $\leq$  10V, their Id limit is doubled.

# = See General Information for Impulse Current Waveform.

**TVS Diodes - Surface Mount - 3000 Watt Specifications - 3.0SMCJ Series Electrical Characteristics - (Continued)**

Part Number*	Uni Part Marking	Bi Part Marking	Breakdown Voltage		@It	Maximum Stand By Current @Vwm+ Id	10/1000µs Maximum Clamping Voltage @Ippm# Vc Max	10/1000µs Rated Peak Impulse Current Ippm#
			Rated Standoff Voltage Vwm	Vbr Min				
			(Volts)	(Volts)				
3.0SMCJ100	HGY	IGY	100.0	111.00	1	5.0	179.0	16.6
3.0SMCJ100A	HGZ	IGZ	100.0	111.00	1	5.0	162.0	18.6
3.0SMCJ110	HHD	IHD	110.0	122.00	1	5.0	196.0	15.4
3.0SMCJ110A	HHE	IHE	110.0	122.00	1	5.0	177.0	16.8
3.0SMCJ120	HHF	IHF	120.0	133.00	1	5.0	214.0	14.0
3.0SMCJ120A	HHG	IHG	120.0	133.00	1	5.0	193.0	15.6
3.0SMCJ130	HHH	IHH	130.0	144.00	1	5.0	231.0	13.0
3.0SMCJ130A	HHK	IHK	130.0	144.00	1	5.0	209.0	14.4
3.0SMCJ150	HHL	IHL	150.0	167.00	1	5.0	268.0	11.2
3.0SMCJ150A	HHM	IHM	150.0	167.00	1	5.0	243.0	12.4
3.0SMCJ160	HHN	IHN	160.0	178.00	1	5.0	287.0	10.4
3.0SMCJ160A	HHP	IHP	160.0	178.00	1	5.0	259.0	11.6
3.0SMCJ170	HHQ	IHQ	170.0	189.00	1	5.0	304.0	9.8
3.0SMCJ170A	HHR	IHR	170.0	189.00	1	5.0	275.0	11.0

\* = Add "C" or "CA" suffix for bidirectional device types.

+ = For Bidirectional Types Having Vwm <= 10V, their Id limit is doubled.

# = See General Information for Impulse Current Waveform.

## TVS Diodes - Surface Mount - 3000 Watt - 3.0SMCJ Series Features

### 3.0SMCJ Series Features

- 3000 watt peak pulse power dissipation
- Available in voltages from 5.0V to 170V
- Unidirectional and bidirectional
- Glass passivated junction
- Low clamping factor
- Each device 100% surge tested

### Absolute Maximum Ratings

- Peak pulse power dissipation (Pppm) at 25°C..... 3000W
- Operating and storage temperatures..... -55°C to + 150°C

### Mechanical Characteristics

- DO214AB package
- UL94V-0 Thermoset Epoxy
- Solder plated terminals
- Solderable per MIL-STD-750 Method 2026

### Mechanical Dimensions

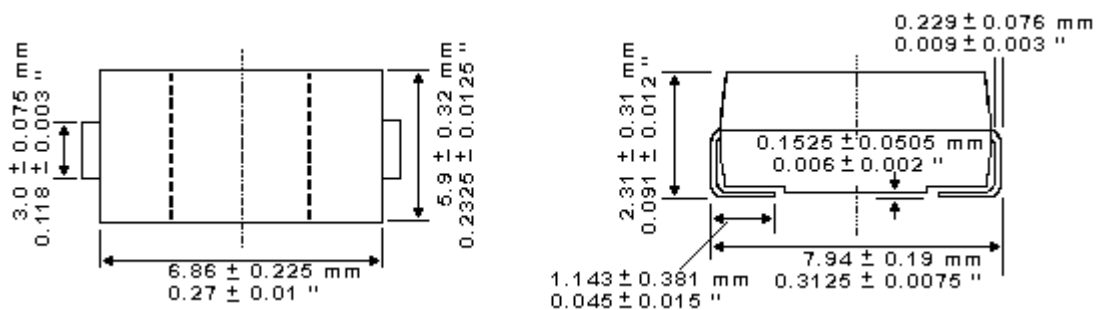

## TVS Diodes - Circuit Examples

### Data Line Protection

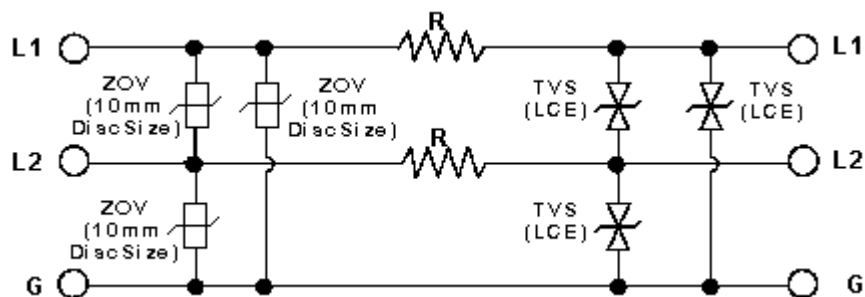

### AC Line Protection

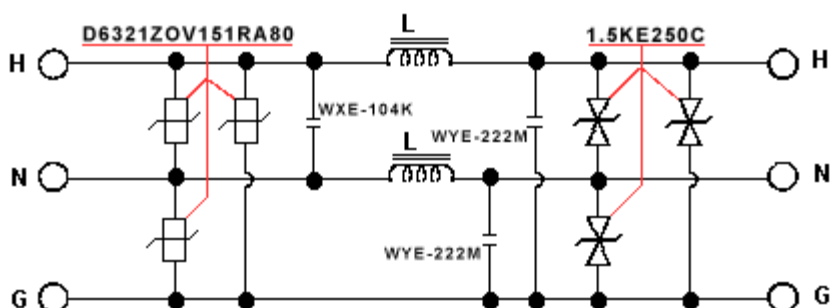

- WXE = World Products RFI Suppressor "X Type" (Across-the-Line)
- WYE = World Products RFI Suppressor "Y Type" (Line-to-Ground)

### Telecom Circuit Protection

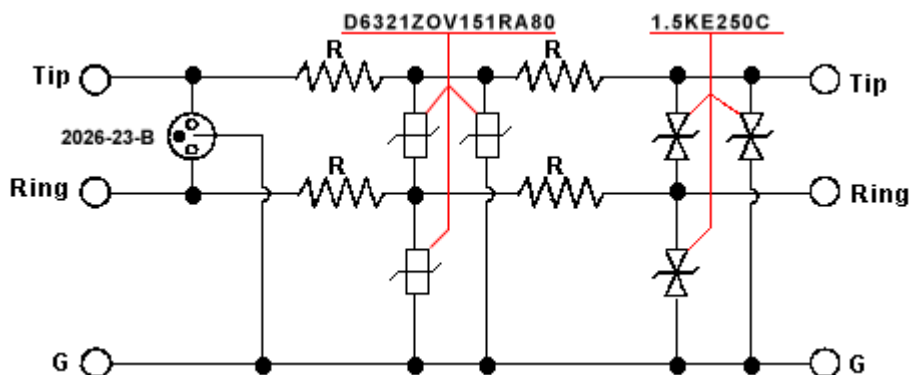

- 2026 = Joslyn Gas Discharge Tubes represented exclusively by World Products.