

**SURFACE MOUNT  
ZENER DIODE**

**REVERSE VOLTAGE – 2.4 to 39 Volts  
POWER DISSIPATION – 0.2 Watts**

- FEATURES**
- Planar die construction
  - 200mW power dissipation rating
- MECHANICAL DATA**
- Case: SOT-323 Plastic
  - Case Material: “Green” molding compound, UL flammability classification 94V-0, (No Br. Sb. Cl)
  - Moisture Sensitivity: Level 1 per J-STD-020D
  - Lead Free in RoHS 2002/95/EC Compliant

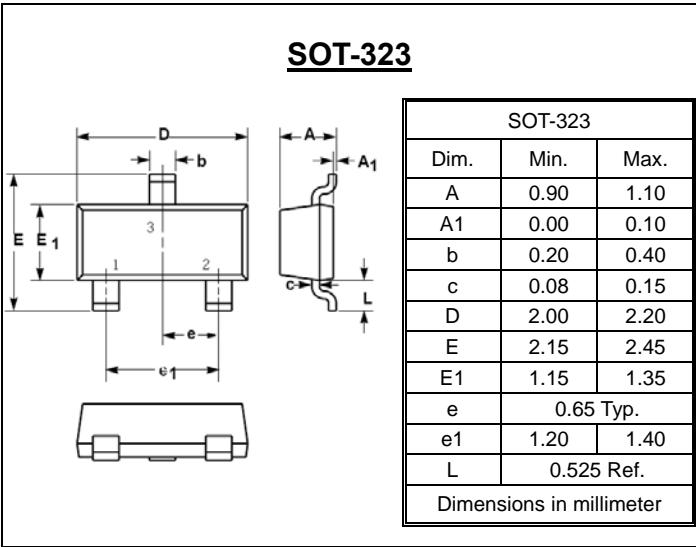

**Maximum Ratings & Thermal Characteristics @ T<sub>A</sub> = 25 unless otherwise specified**

Characteristic	Symbol	Value	Unit
Forward Voltage @ I <sub>F</sub> =10mA	V <sub>F</sub>	0.9	V
Power Dissipation	P <sub>D</sub>	200	mW
Thermal Resistance, Junction to Ambient	R <sub>JA</sub>	625	/W
Operating Temperature Range	T <sub>J</sub>	150	
Storage Temperature Range	T <sub>STG</sub>	-65~+150	

**Device Marking :**

Device P/N	Marking	Pin Diagram	Equivalent Circuit Diagram
MMBZ5221BW	XXX=Specific device code (See below table)		

**Electrical Characteristics @ T<sub>A</sub> = 25 unless otherwise specified**

Symbol	Parameter
V <sub>Z</sub>	Reverse Zener Voltage @ I <sub>ZT</sub>
I <sub>ZT</sub>	Reverse Current
Z <sub>ZT</sub>	Maximum Zener Impedance @ I <sub>ZT</sub>
I <sub>ZK</sub>	Reverse Current
Z <sub>ZK</sub>	Maximum Zener Impedance @ I <sub>ZK</sub>
I <sub>R</sub>	Reverse Leakage Current @ V <sub>R</sub>
V <sub>R</sub>	Reverse Voltage
I <sub>F</sub>	Forward Current
V <sub>F</sub>	Forward Voltage @ I <sub>F</sub>

Device	Device marking	Zener Voltage				Maximum Zener Impedance		Maximum Reverse Current	
		VZ@IZT			IZT	ZZT@IZT	ZZK @IZK=0.25mA	IR @VR	
		Nom	Min	Max	mA	Ω	Ω	uA	V
MMBZ5221BW	KC1	2.4	2.28	2.52	20	30	1200	100	1.0
MMBZ5223BW	KC3	2.7	2.57	2.84	20	30	1300	75	1.0
MMBZ5225BW	KC5	3.0	2.85	3.15	20	30	1600	50	1.0
MMBZ5226BW	KG1	3.3	3.14	3.47	20	28	1600	25	1.0
MMBZ5227BW	KG2	3.6	3.42	3.78	20	24	1700	15	1.0
MMBZ5228BW	KG3	3.9	3.71	4.10	20	23	1900	10	1.0
MMBZ5229BW	KG4	4.3	4.09	4.52	20	22	2000	5.0	1.0
MMBZ5230BW	KG5	4.7	4.47	4.94	20	19	1900	5.0	2.0
MMBZ5231BW	KE1	5.1	4.85	5.36	20	17	1600	5.0	2.0
MMBZ5232BW	KE2	5.6	5.32	5.88	20	11	1600	5.0	3.0
MMBZ5233BW	KE3	6.0	5.70	6.30	20	7	1600	5.0	3.5
MMBZ5234BW	KE4	6.2	5.89	6.51	20	7	1000	5.0	4.0
MMBZ5235BW	KE5	6.8	6.46	7.14	20	5	750	3.0	5.0
MMBZ5236BW	KF1	7.5	7.13	7.88	20	6	500	3.0	6.0
MMBZ5237BW	KF2	8.2	7.79	8.61	20	8	500	3.0	6.5
MMBZ5238BW	KF3	8.7	8.27	9.14	20	8	600	3.0	6.5
MMBZ5239BW	KF4	9.1	8.65	9.56	20	10	600	3.0	7.0
MMBZ5240BW	KF5	10	9.50	10.50	20	17	600	3.0	8.0
MMBZ5241BW	KH1	11	10.45	11.55	20	22	600	2.0	8.4
MMBZ5242BW	KH2	12	11.40	12.60	20	30	600	1.0	9.1
MMBZ5243BW	KH3	13	12.35	13.65	9.5	13	600	0.5	9.9
MMBZ5245BW	KH5	15	14.25	15.75	8.5	16	600	0.1	11
MMBZ5246BW	KJ1	16	15.20	16.80	7.8	17	600	0.1	12
MMBZ5248BW	KJ3	18	17.10	18.90	7.0	21	600	0.1	14
MMBZ5250BW	KJ5	20	19.00	21.00	6.2	25	600	0.1	15
MMBZ5251BW	KK1	22	20.90	23.10	5.6	29	600	0.1	17
MMBZ5252BW	KK2	24	22.80	25.20	5.2	33	600	0.1	18
MMBZ5254BW	KK4	27	25.65	28.35	5.0	41	600	0.1	21
MMBZ5255BW	KK5	28	26.60	29.40	4.5	44	600	0.1	21
MMBZ5256BW	KM1	30	28.50	31.50	4.2	49	600	0.1	23
MMBZ5257BW	KM2	33	31.35	34.65	3.8	58	700	0.1	25
MMBZ5258BW	KM3	36	34.20	37.80	3.4	70	700	0.1	27
MMBZ5259BW	KM4	39	37.05	40.95	3.2	80	800	0.1	30

REV. 0, May-2009, KSJR10

**Notes:**

1. Short duration test pulse used to minimize self-heating effect.
2. f = 1KHz.

## MMBZ52xBW Series Typical Characteristics

**Fig.1 Power Derating Curve**

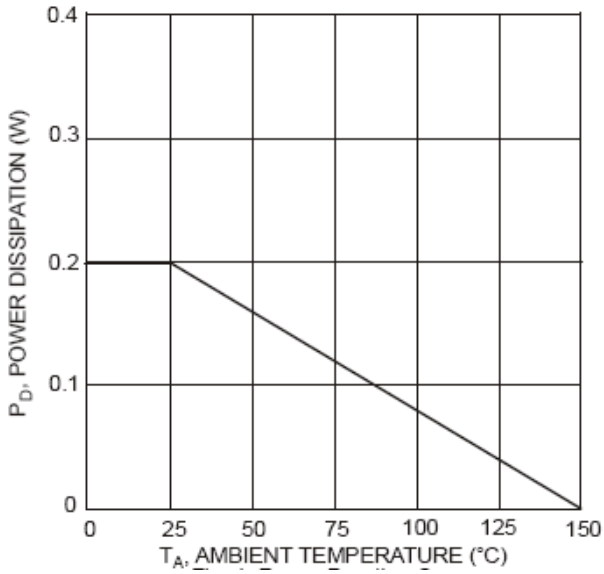

**Fig.2 Typical Zener Breakdown Characteristics**

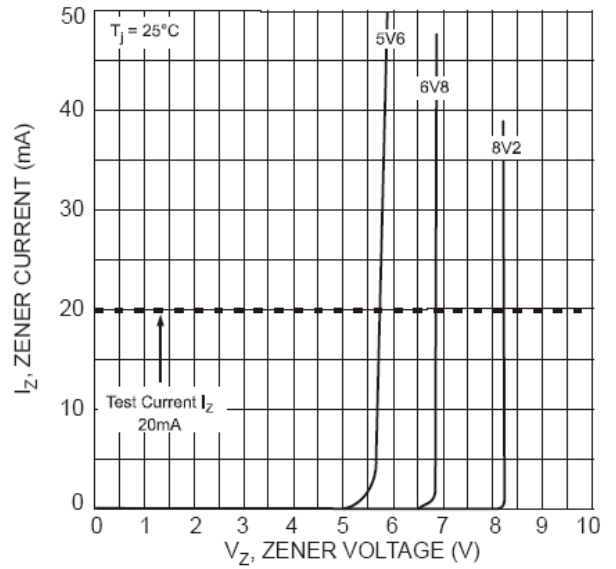

**Fig.3 Typical Zener Breakdown Characteristics**

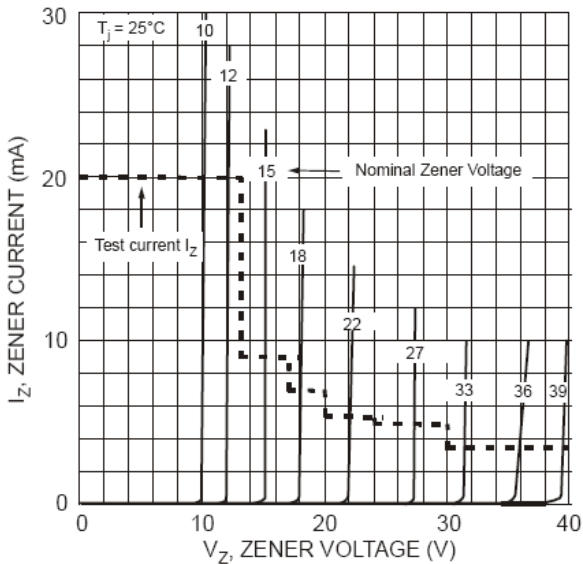

**Fig.4 Typical Total Capacitance vs. Nominal Zener Voltage**

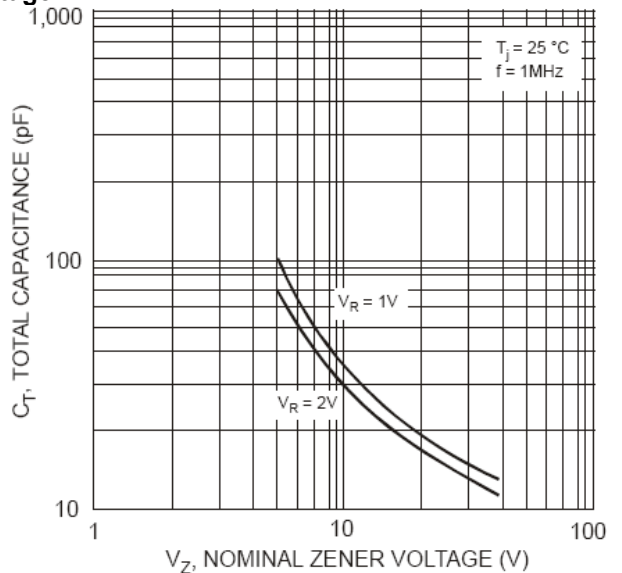

**Fig.5 Typical Zener Impedance Characteristics**

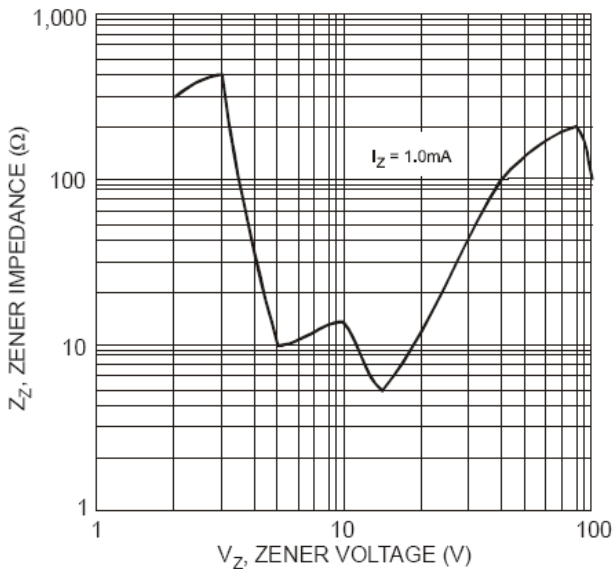

**Fig.6 Maximum Non-repetitive Surge Power**

