

AM26LS31C QUADRUPLE DIFFERENTIAL LINE DRIVER

SLLS114C - JANUARY 1979 - REVISED MAY 1995

- Meets or Exceeds the Requirements of ANSI EIA/TIA-422-B and ITU Recommendation V.11
- Operates From a Single 5-V Supply
- TTL Compatible
- Complementary Outputs
- High Output Impedance in Power-Off Conditions
- Complementary Output Enable Inputs

description

The AM26LS31C is a quadruple complementary-output line driver designed to meet the requirements of ANSI EIA/TIA-422-B and ITU (formerly CCITT) V.11. The 3-state outputs have high-current capability for driving balanced lines such as twisted-pair or parallel-wire transmission lines, and they provide a high-impedance state in the power-off condition. The enable function is common to all four drivers and offers the choice of an active-high or active-low enable input. Low-power Schottky circuitry reduces power consumption without sacrificing speed.

The AM26LS31C is characterized for operation from 0°C to 70°C.

D OR N PACKAGE (TOP VIEW)

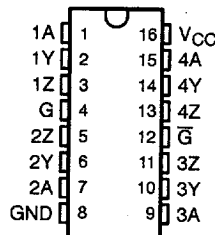

FUNCTION TABLE (each driver)

INPUT A	ENABLES		OUTPUTS	
	G	\bar{G}	Y	Z
H	H	X	H	L
L	H	X	L	H
H	X	L	H	L
L	X	L	L	H
X	L	H	Z	Z

H = high level
L = low level
X = irrelevant
Z = high impedance (off)

logic symbol

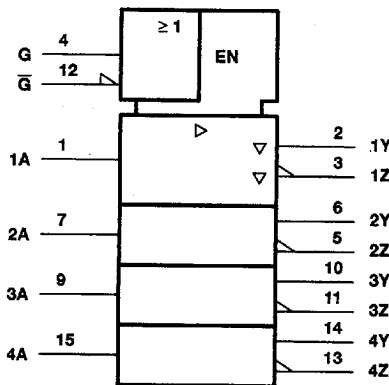

† This symbol is in accordance with ANSI/IEEE Std 91-1984 and IEC Publication 617-12.

logic diagram (positive logic)

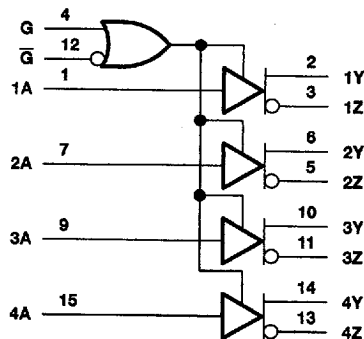

PRODUCTION DATA Information is current as of publication date. Products conform to specifications per the terms of Texas Instruments standard warranty. Production processing does not necessarily include testing of all parameters.

**TEXAS
INSTRUMENTS**

POST OFFICE BOX 655303 • DALLAS, TEXAS 75265

Copyright © 1985, Texas Instruments Incorporated

8961724 0098267 879

2-19

AM26LS31C QUADRUPLE DIFFERENTIAL LINE DRIVER

SLLS114C - JANUARY 1979 - REVISED MAY 1995

schematic (each driver)

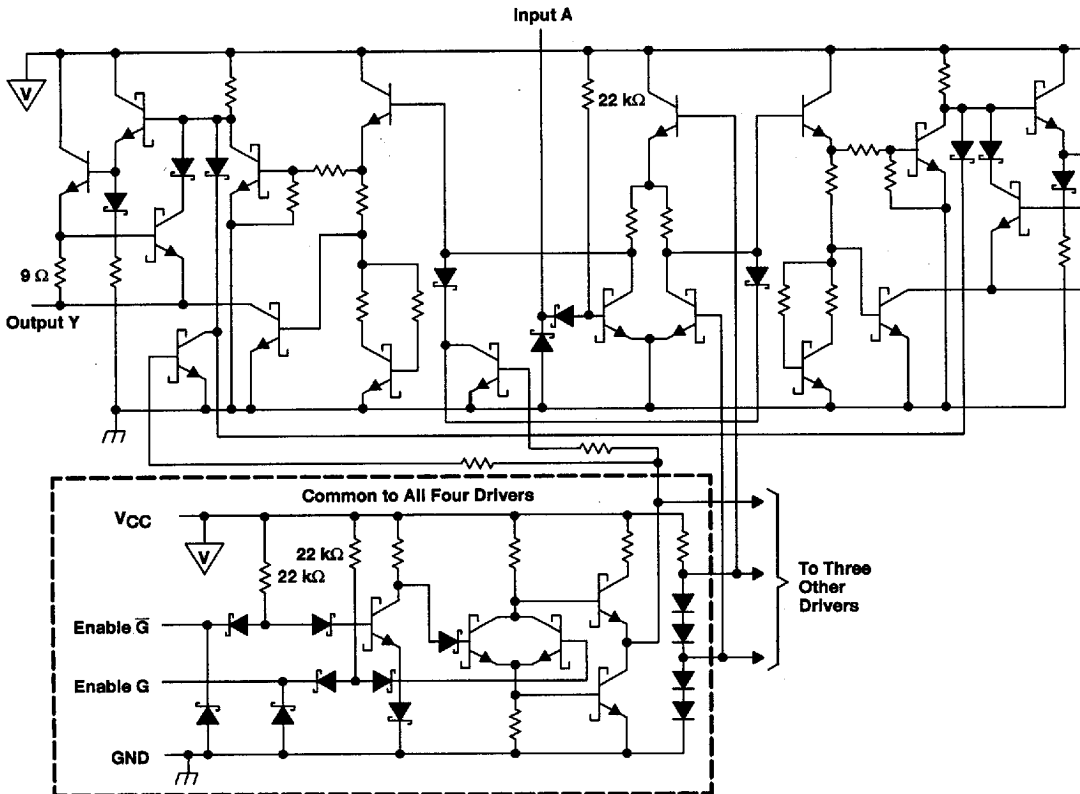

All resistor values are nominal.

absolute maximum ratings over operating free-air temperature range (unless otherwise noted)†

Supply voltage, V_{CC} (see Note 1)	7 V
Input voltage, V_I	7 V
Output off-state voltage	5.5 V
Continuous total power dissipation	See Dissipation Rating Table
Operating free-air temperature range, T_A	0°C to 70°C
Storage temperature range, T_{stg}	-65°C to 150°C
Lead temperature 1,6 mm (1/16 inch) from case for 10 seconds	260°C

† Stresses beyond those listed under "absolute maximum ratings" may cause permanent damage to the device. These are stress ratings only, and functional operation of the device at these or any other conditions beyond those indicated under "recommended operating conditions" is not implied. Exposure to absolute-maximum-rated conditions for extended periods may affect device reliability.

NOTE 1: All voltage values, except differential output voltage V_{OD} , are with respect to network GND.

8961724 0098268 705

**TEXAS
INSTRUMENTS**

POST OFFICE BOX 655303 • DALLAS, TEXAS 75265

2-20

AM26LS31C QUADRUPLE DIFFERENTIAL LINE DRIVER

SLLS114C—JANUARY 1979—REVISED MAY 1995

DISSIPATION RATING TABLE

PACKAGE	$T_A \leq 25^\circ\text{C}$ POWER RATING	DERATING FACTOR ABOVE $T_A = 25^\circ\text{C}$	$T_A = 70^\circ\text{C}$ POWER RATING
D	950 mW	7.6 mW/ $^\circ\text{C}$	608 mW
N	1150 mW	9.2 mW/ $^\circ\text{C}$	736 mW

recommended operating conditions

	MIN	NOM	MAX	UNIT
Supply voltage, V_{CC}	4.75	5	5.25	V
High-level input voltage, V_{IH}	2			V
Low-level input voltage, V_{IL}	0.8			V
High-level output current, I_{OH}	-20			mA
Low-level output current, I_{OL}	20			mA
Operating free-air temperature, T_A	0	70		$^\circ\text{C}$

electrical characteristics over operating free-air temperature range (unless otherwise noted)

PARAMETER		TEST CONDITIONS	MIN	TYP†	MAX	UNIT
V_{IK}	Input clamp voltage	$V_{CC} = 4.75\text{ V}$, $I_I = -18\text{ mA}$			-1.5	V
V_{OH}	High-level output voltage	$V_{CC} = 4.75\text{ V}$, $I_{OH} = -20\text{ mA}$	2.5			V
V_{OL}	Low-level output voltage	$V_{CC} = 4.75\text{ V}$, $I_{OL} = 20\text{ mA}$			0.5	V
I_{OZ}	Off-state (high-impedance-state) output current	$V_{CC} = 4.75\text{ V}$ $V_O = 0.5\text{ V}$ $V_O = 2.5\text{ V}$			-20 20	μA
I_I	Input current at maximum input voltage	$V_{CC} = 5.25\text{ V}$, $V_I = 7\text{ V}$			0.1	mA
I_{IH}	High-level input current	$V_{CC} = 5.25\text{ V}$, $V_I = 2.7\text{ V}$			20	μA
I_{IL}	Low-level input current	$V_{CC} = 5.25\text{ V}$, $V_I = 0.4\text{ V}$			-0.36	mA
I_{OS}	Short-circuit output current‡	$V_{CC} = 5.25\text{ V}$	-30		-150	mA
I_{CC}	Supply current	$V_{CC} = 5.25\text{ V}$, All outputs disabled		32	80	mA

† All typical values are at $V_{CC} = 5\text{ V}$ and $T_A = 25^\circ\text{C}$.

‡ Not more than one output should be shorted at a time, and duration of the short circuit should not exceed one second.

switching characteristics, $V_{CC} = 5\text{ V}$, $T_A = 25^\circ\text{C}$

PARAMETER		TEST CONDITIONS	MIN	TYP	MAX	UNIT
t_{PLH}	Propagation delay time, low-to-high-level output	$C_L = 30\text{ pF}$, See Figure 1 S1 and S2 open,		14	20	ns
t_{PHL}	Propagation delay time, high-to-low-level output			14	20	ns
	Output-to-output skew			1	6	ns
t_{PZH}	Output enable time to high level	$C_L = 30\text{ pF}$, See Figure 1 $R_L = 75\ \Omega$,		25	40	ns
t_{PZL}	Output enable time to low level	$C_L = 30\text{ pF}$, See Figure 1 $R_L = 180\ \Omega$,		37	45	ns
t_{PHZ}	Output disable time from high level	$C_L = 10\text{ pF}$, See Figure 1 S1 and S2 closed,		21	30	ns
t_{PLZ}	Output disable time from low level			23	35	ns



POST OFFICE BOX 655303 • DALLAS, TEXAS 75265

2-21

■ 8961724 0098269 641 ■

AM26LS31C QUADRUPLE DIFFERENTIAL LINE DRIVER

SLLS114C - JANUARY 1979 - REVISED MAY 1995

PARAMETER MEASUREMENT INFORMATION

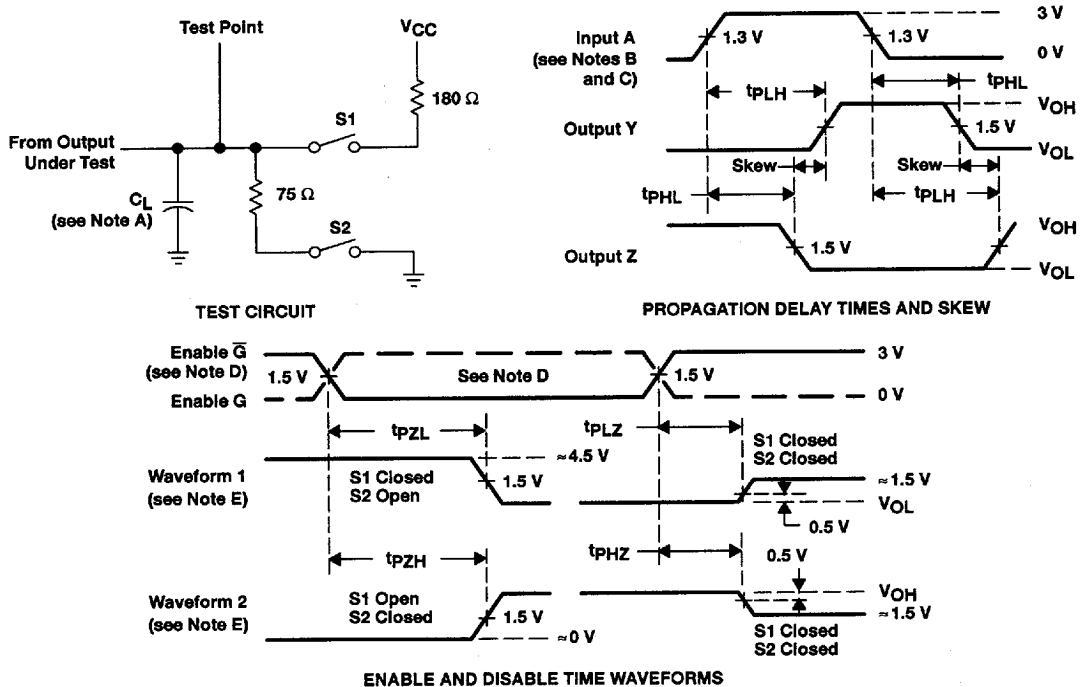

- NOTES: A. C_L includes probe and jig capacitance.
 B. All input pulses are supplied by generators having the following characteristics: $PRR \leq 1$ MHz, $Z_O \approx 50 \Omega$, $t_r \leq 15$ ns, and $t_f \leq 6$ ns.
 C. When measuring propagation delay times and skew, switches S1 and S2 are open.
 D. Each enable is tested separately.
 E. Waveform 1 is for an output with internal conditions such that the output is low except when disabled by the output control. Waveform 2 is for an output with internal conditions such that the output is high except when disabled by the output control.

Figure 1. Test Circuit and Voltage Waveforms

8961724 0098270 363

**TEXAS
INSTRUMENTS**

POST OFFICE BOX 655303 • DALLAS, TEXAS 75265

TYPICAL CHARACTERISTICS

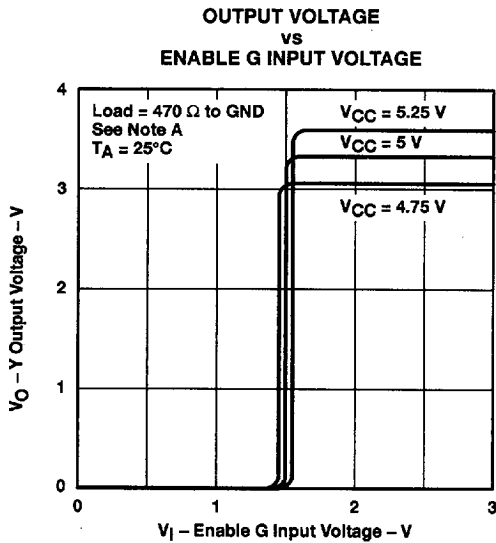

Figure 2

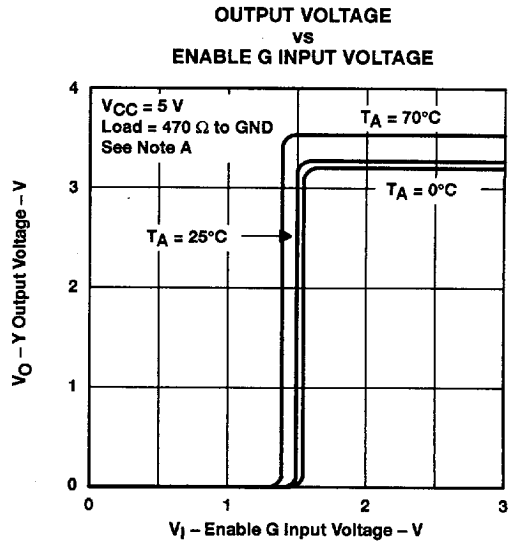

Figure 3

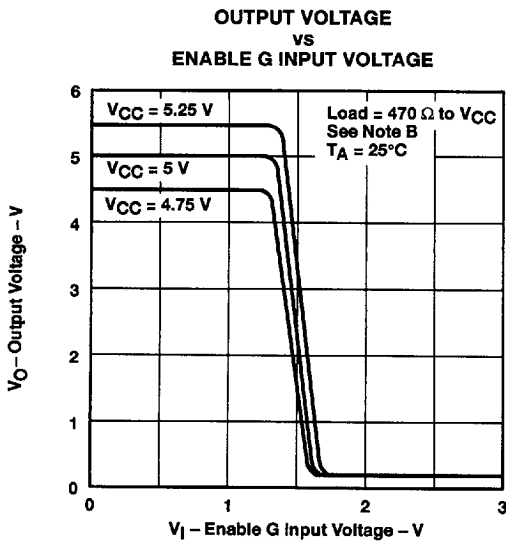

Figure 4

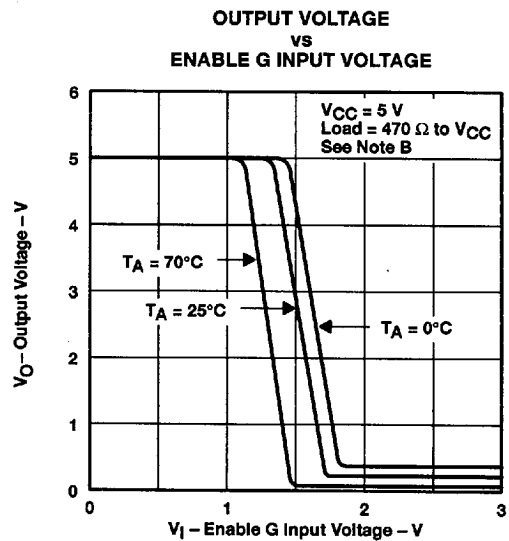

Figure 5

NOTES: A. The A input is connected to V_{CC} during the testing of the Y outputs and to ground during testing of the Z outputs.
 B. The A input is connected to ground during the testing of the Y outputs and to V_{CC} during the testing of the Z outputs.

AM26LS31C QUADRUPLE DIFFERENTIAL LINE DRIVER

SLLS114C - JANUARY 1979 - REVISED MAY 1995

TYPICAL CHARACTERISTICS

**HIGH-LEVEL OUTPUT VOLTAGE
vs
FREE-AIR TEMPERATURE**

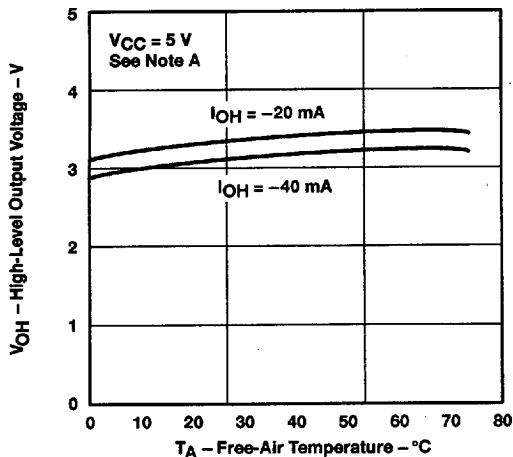

Figure 6

**HIGH-LEVEL OUTPUT VOLTAGE
vs
HIGH-LEVEL OUTPUT CURRENT**

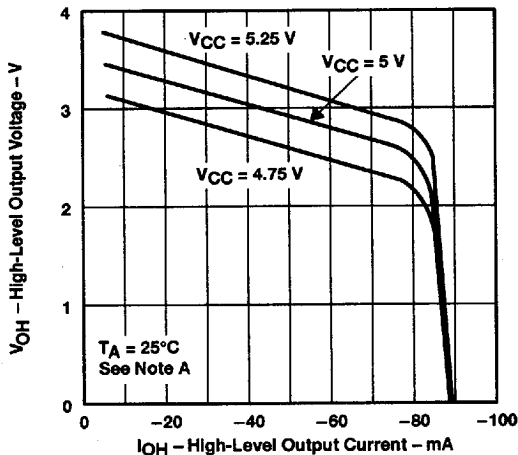

Figure 7

**LOW-LEVEL OUTPUT VOLTAGE
vs
FREE-AIR TEMPERATURE**

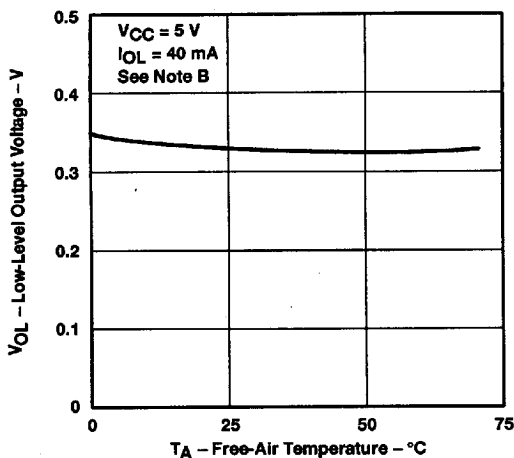

Figure 8

**LOW-LEVEL OUTPUT VOLTAGE
vs
LOW-LEVEL OUTPUT CURRENT**

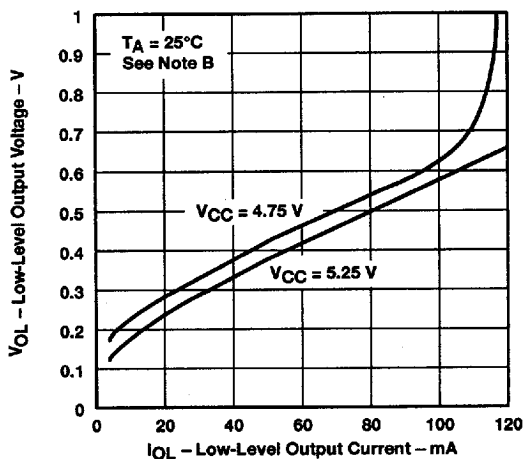

Figure 9

NOTES: A. The A input is connected to V_{CC} during the testing of the Y outputs and to ground during testing of the Z outputs.
B. The A input is connected to ground during the testing of the Y outputs and to V_{CC} during the testing of the Z inputs.

8961724 0098272 136

**TEXAS
INSTRUMENTS**

POST OFFICE BOX 655303 • DALLAS, TEXAS 75265

AM26LS31C QUADRUPLE DIFFERENTIAL LINE DRIVER

SLLS114C - JANUARY 1979 - REVISED MAY 1995

TYPICAL CHARACTERISTICS

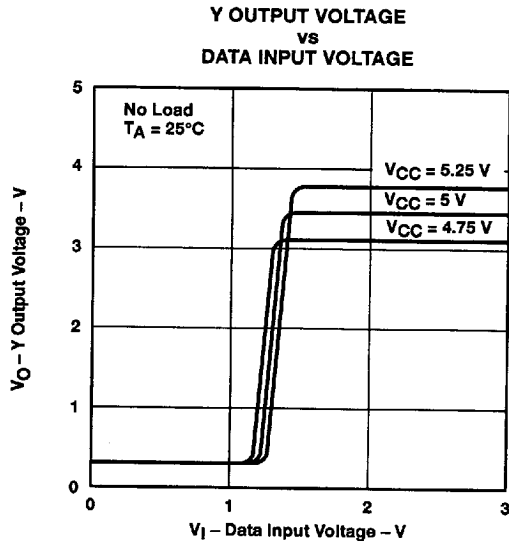

Figure 10

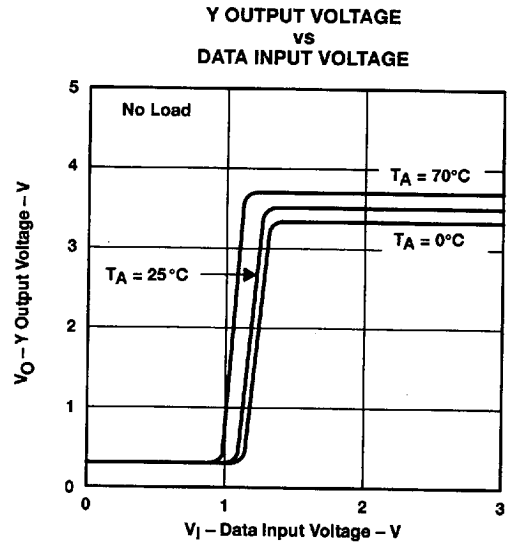

Figure 11

8961724 0098273 072

 **TEXAS
INSTRUMENTS**
POST OFFICE BOX 655303 • DALLAS, TEXAS 75265

2-25